

# **Fatigue and Fracture**

## **Factors Influencing Fatigue Mean Stress**

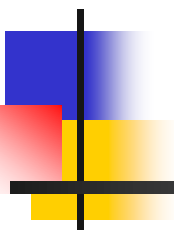

---

**Professor Darrell F. Socie**  
**Mechanical Science and Engineering**  
**University of Illinois**

© 2004-2013 Darrell Socie, All Rights Reserved



# Factors Influencing Fatigue

---

- **Mean Stress**
- Variable Amplitude
- Stress Concentrations
- Surface Finish

# Mean Stresses

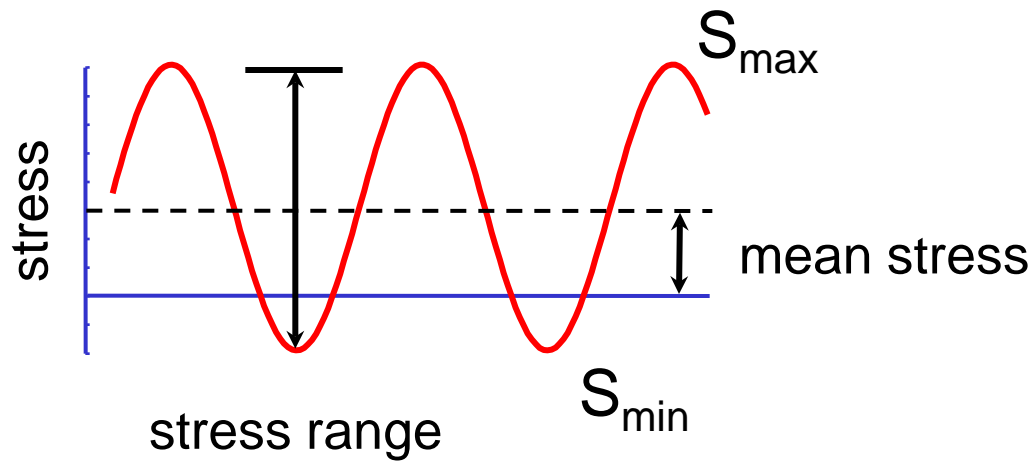

$$S_{\text{mean}} = \frac{S_{\max} + S_{\min}}{2}$$

$$R = \frac{S_{\min}}{S_{\max}}$$



# General Observations

---

- Tensile mean stresses reduce the fatigue life or decrease the allowable stress range
- Compressive mean stresses increase the fatigue life or increase the allowable stress range

# Mechanism

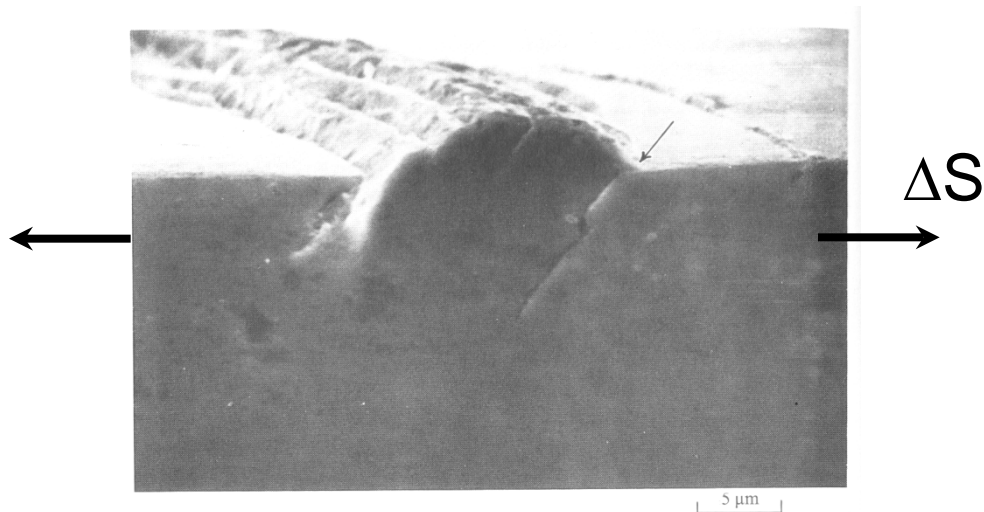

Fatigue damage is a shear process

Tensile mean stresses open microcracks and make sliding easier

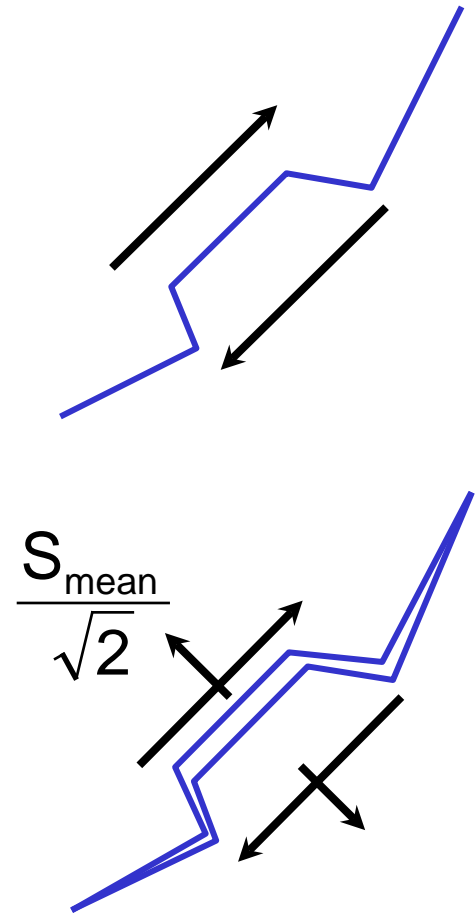

# Goodman 1890

*Mechanics Applied to Engineering*  
John Goodman, 1890

“.. whether the assumptions of the theory are justifiable or not .... We adopt it simply because it is the easiest to use, and for all practical purposes, represents Wöhlers data.

$$S_{\text{ultimate}} = S_{\text{min}} + 2 \Delta S$$

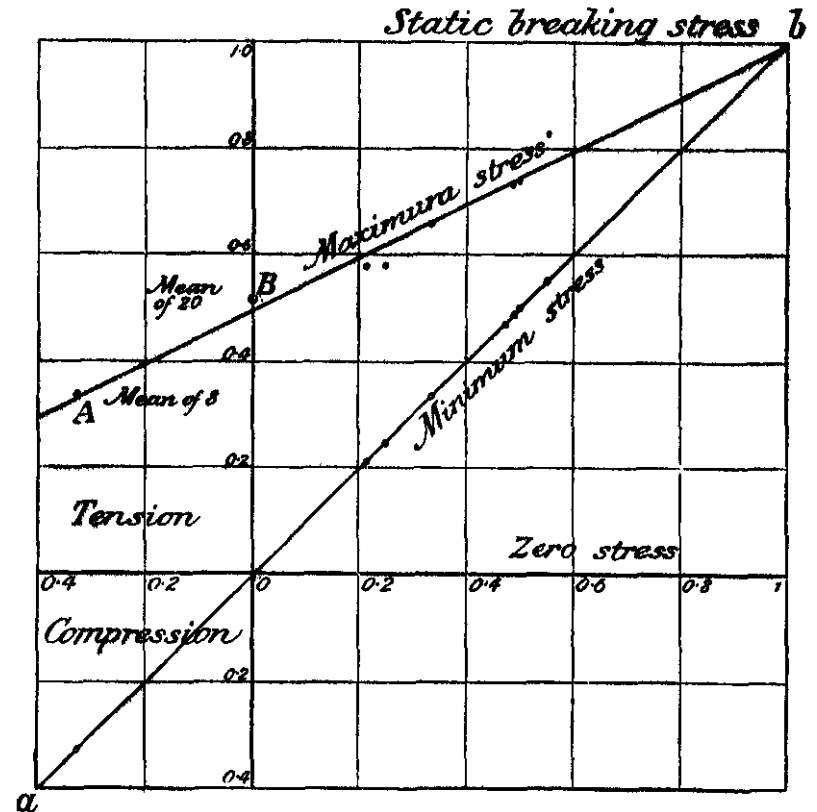
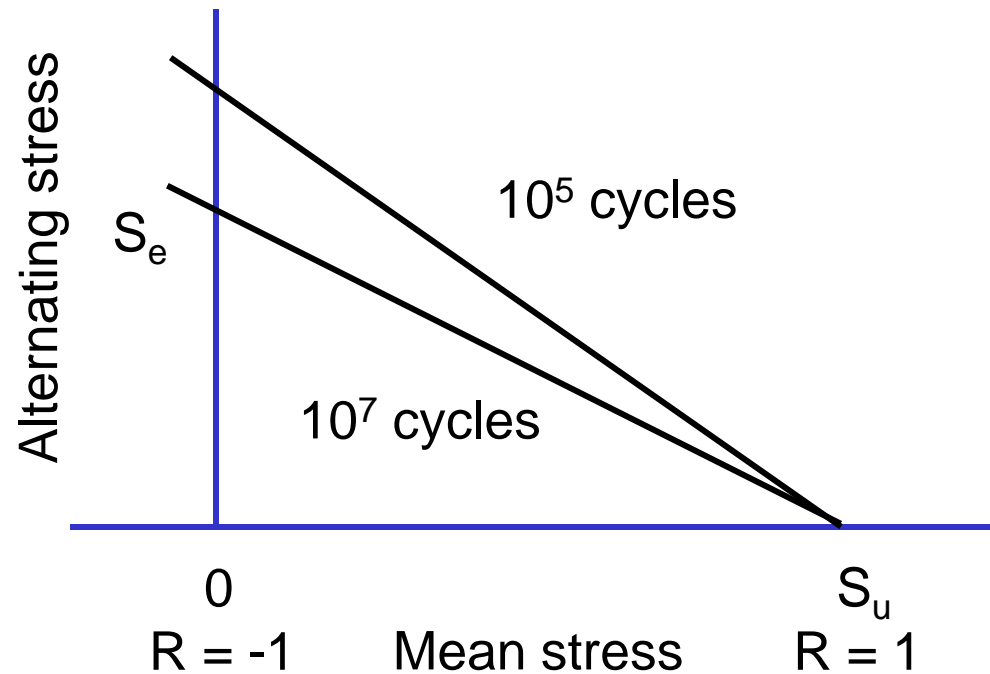

FIG. 517.

# Goodman Diagram



$$\frac{\Delta S}{2} = \left( \frac{\Delta S}{2} \right)_{R=-1} \left( 1 - \frac{S_{\text{mean}}}{S_{\text{ultimate}}} \right)$$

# Test Data ( 1941 )

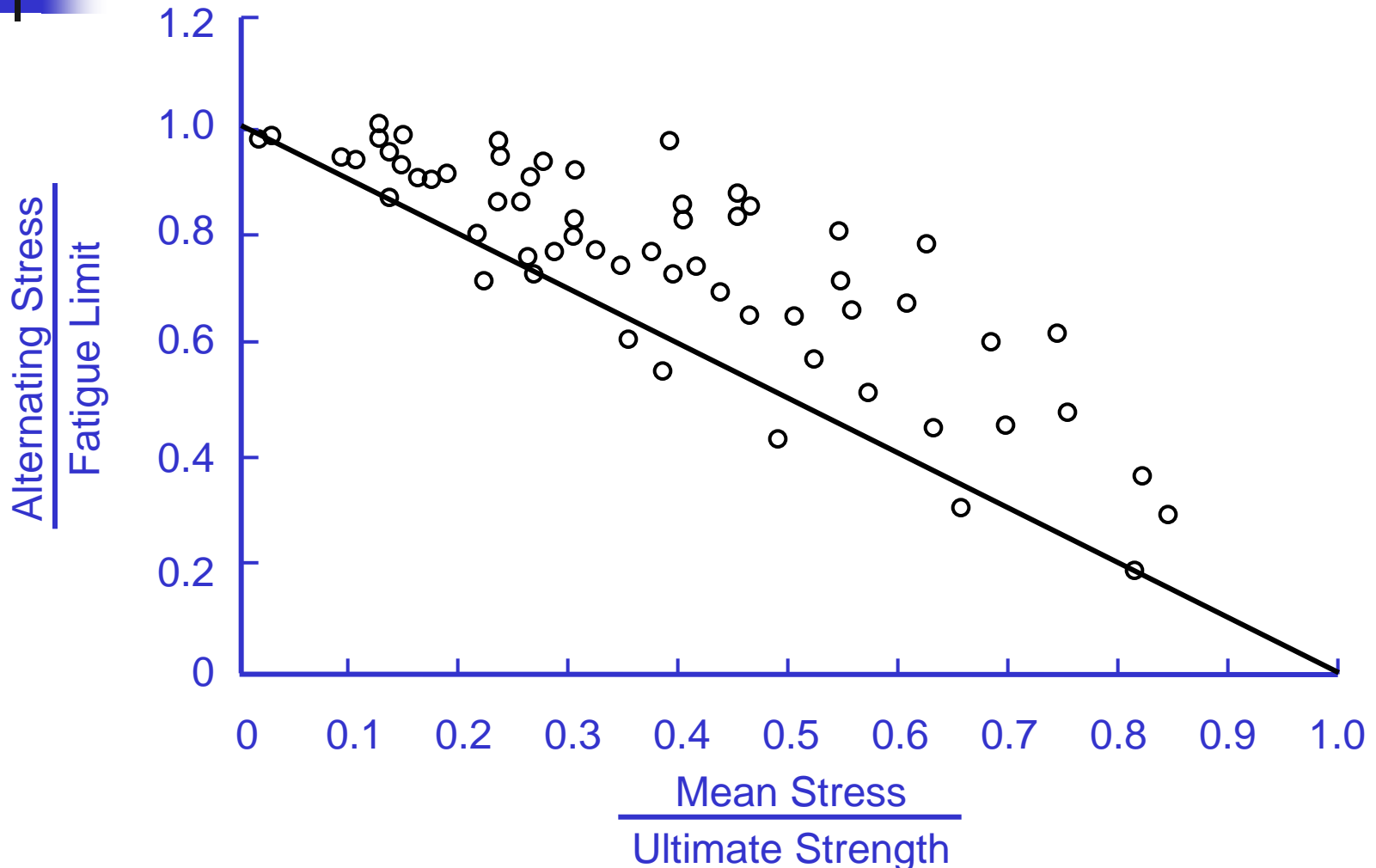

J.O. Smith, The Effect of Range of Stress on the Fatigue Strength of Metals,  
Engineering Experiment Station Bulletin 334, University of Illinois, 1941



# Compression

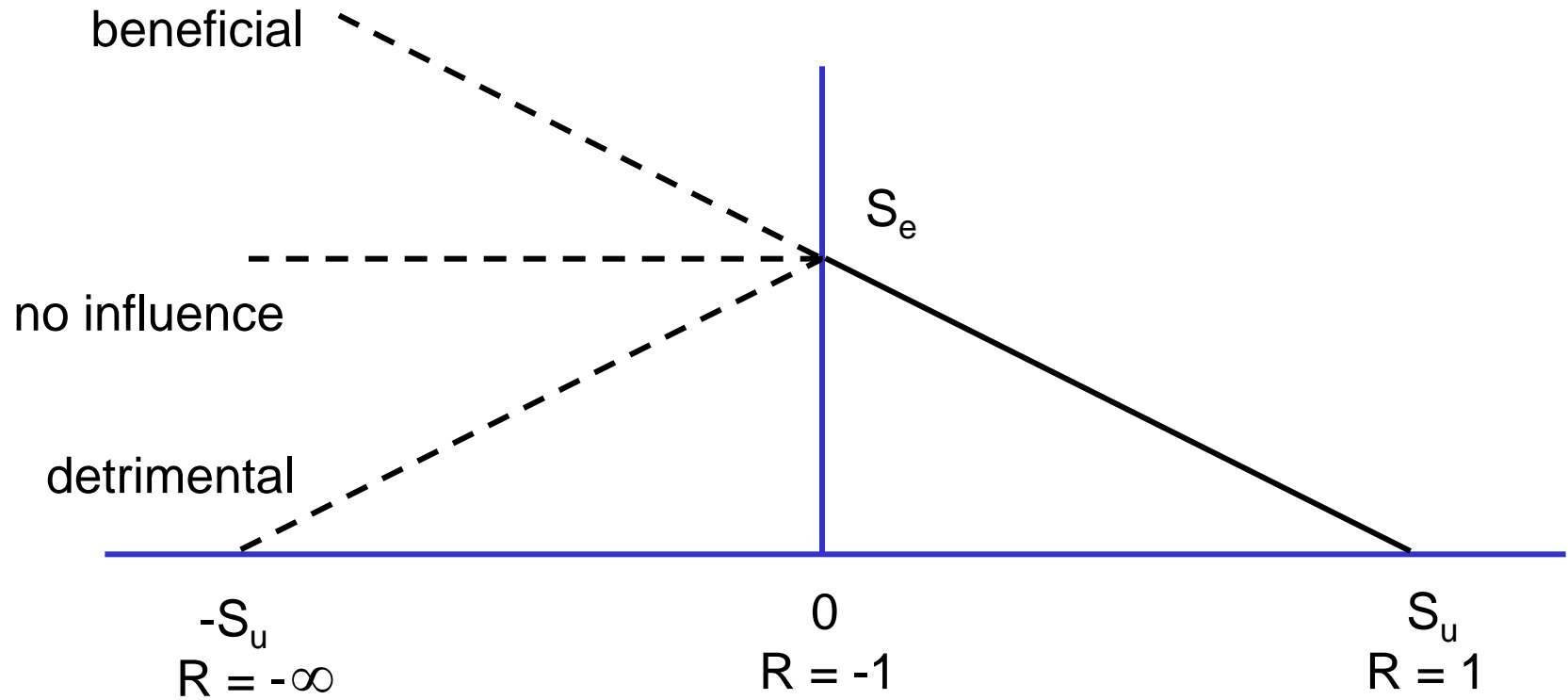

# Modified Goodman ( no yielding )

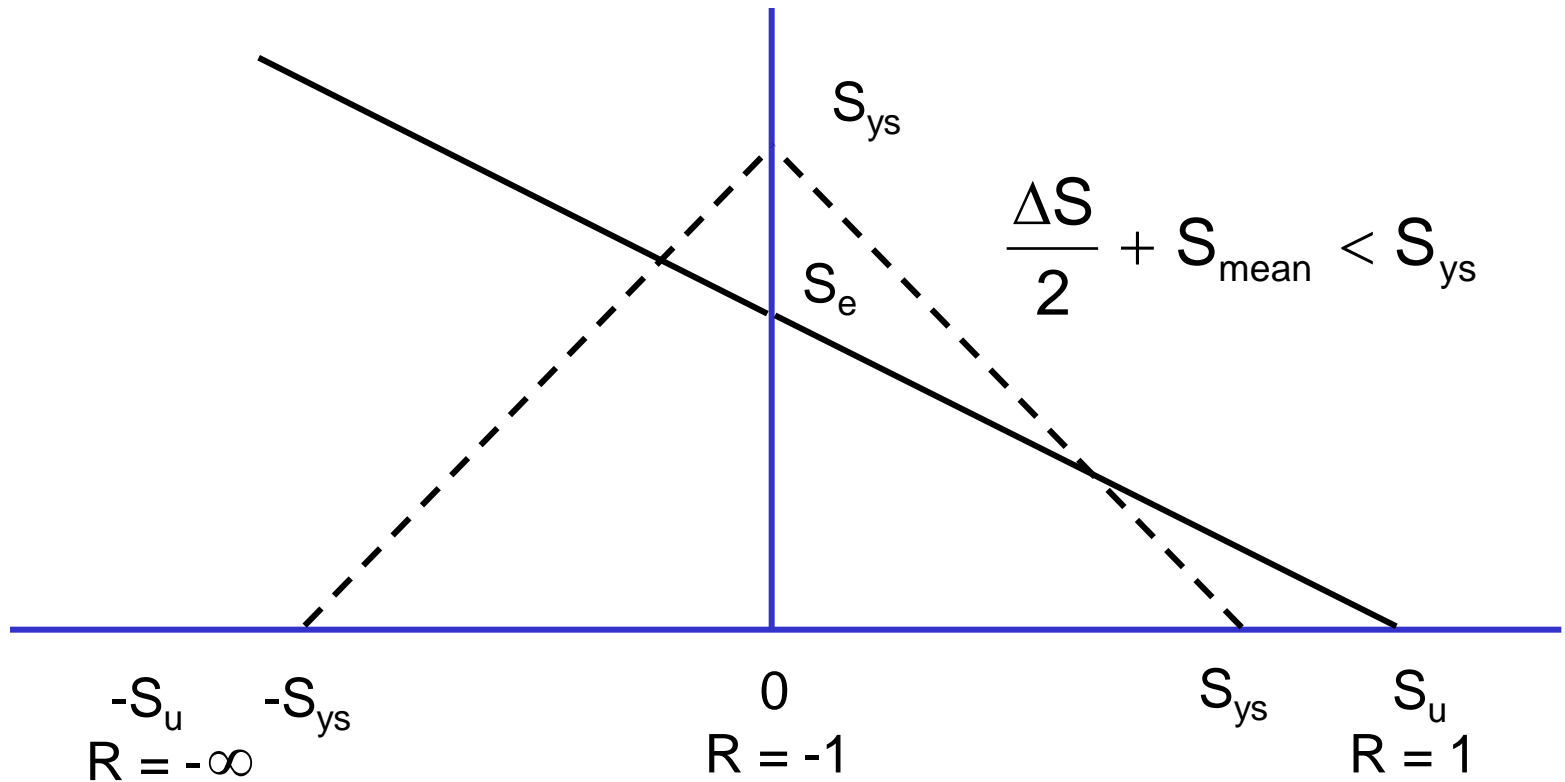

# Mean Stress Influence on Life

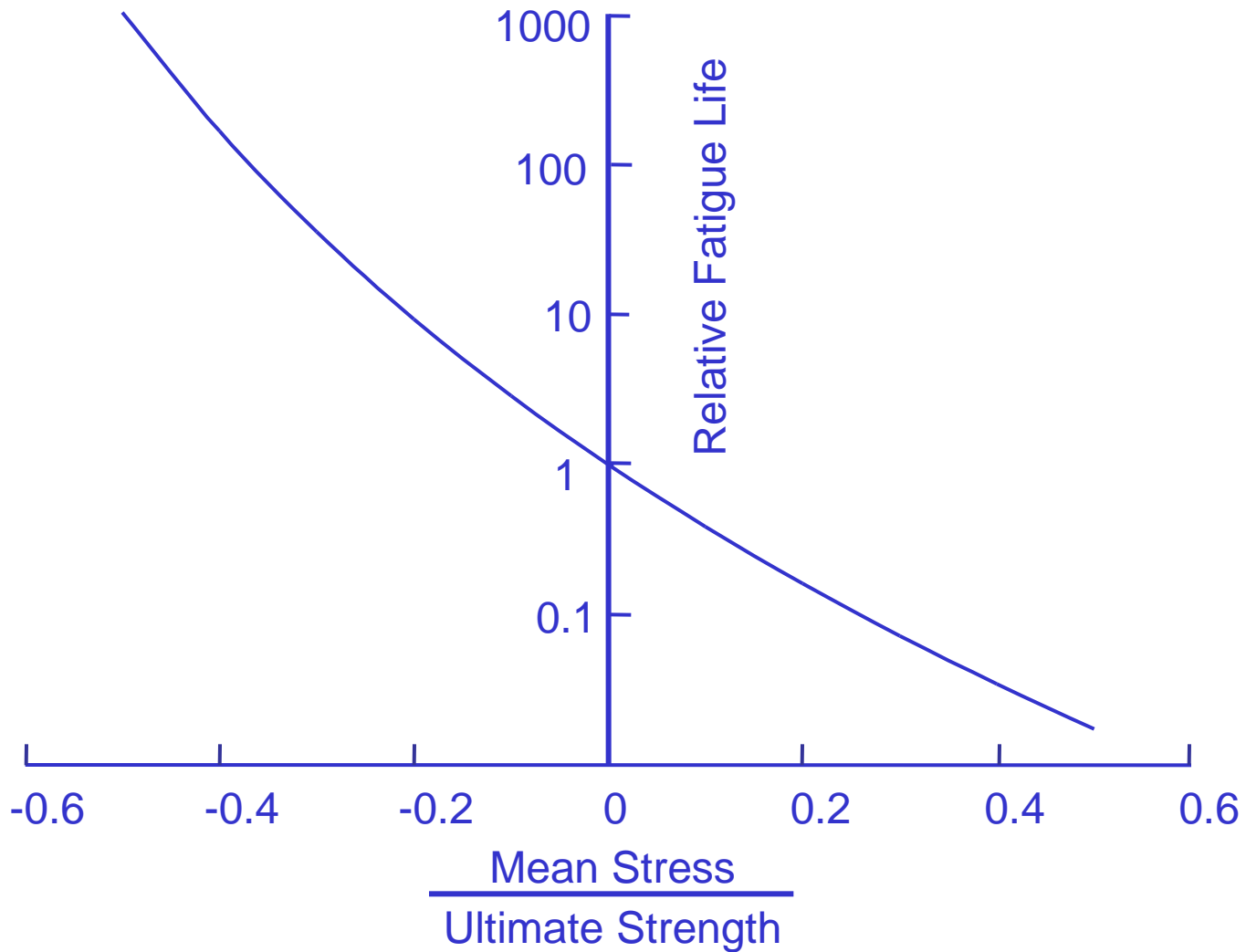

# Stress Concentrations

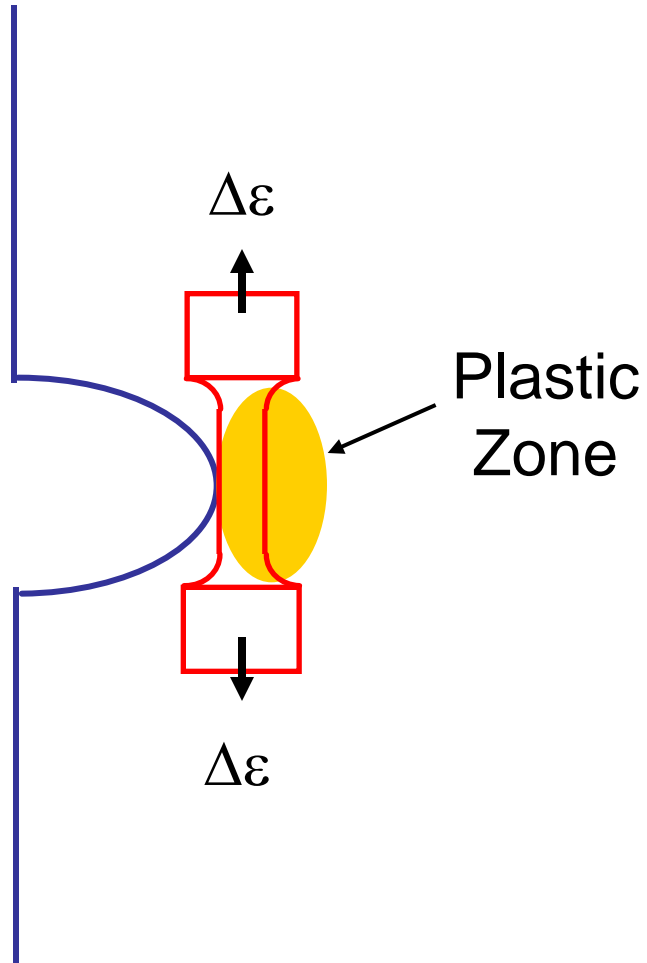

The elastic material surrounding the plastic zone around a stress concentration forces the material to deform in strain control

# Mean Stresses at Notches

elastic

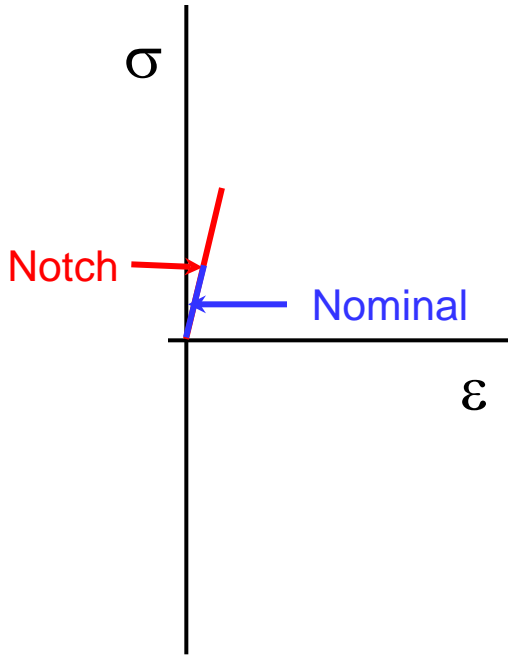

Nominal mean stress is less than notch mean stress

plastic

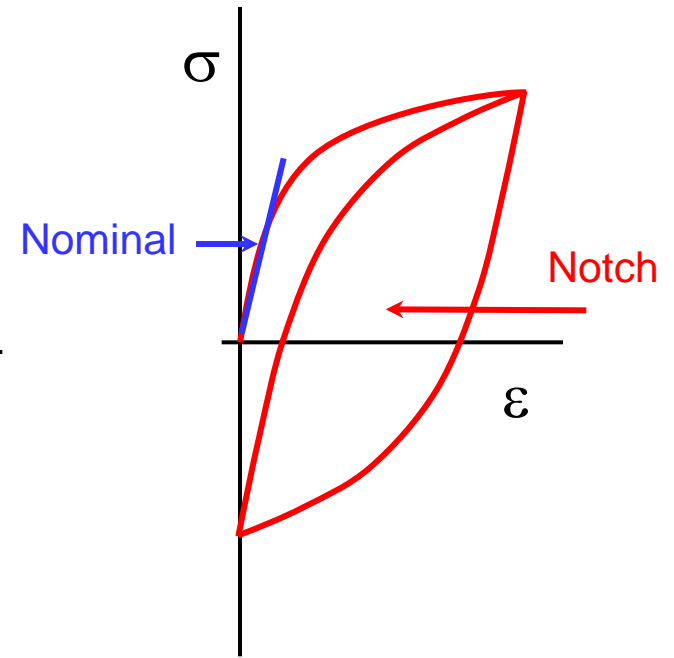
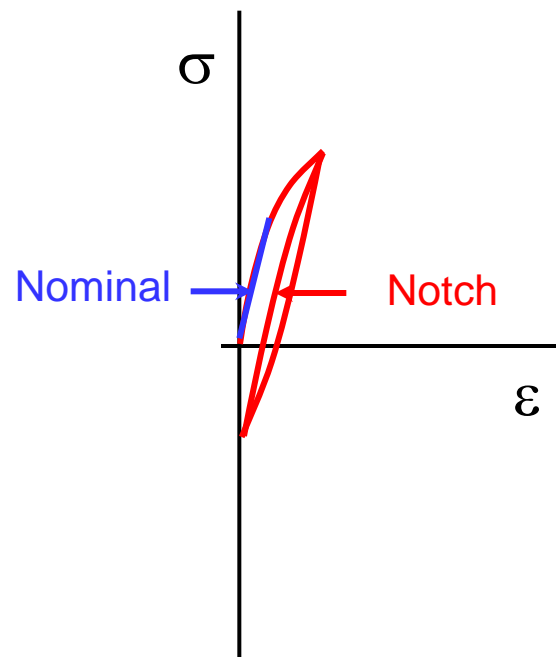

Nominal mean stress is greater than notch mean stress

# Morrow Mean Stress Correction

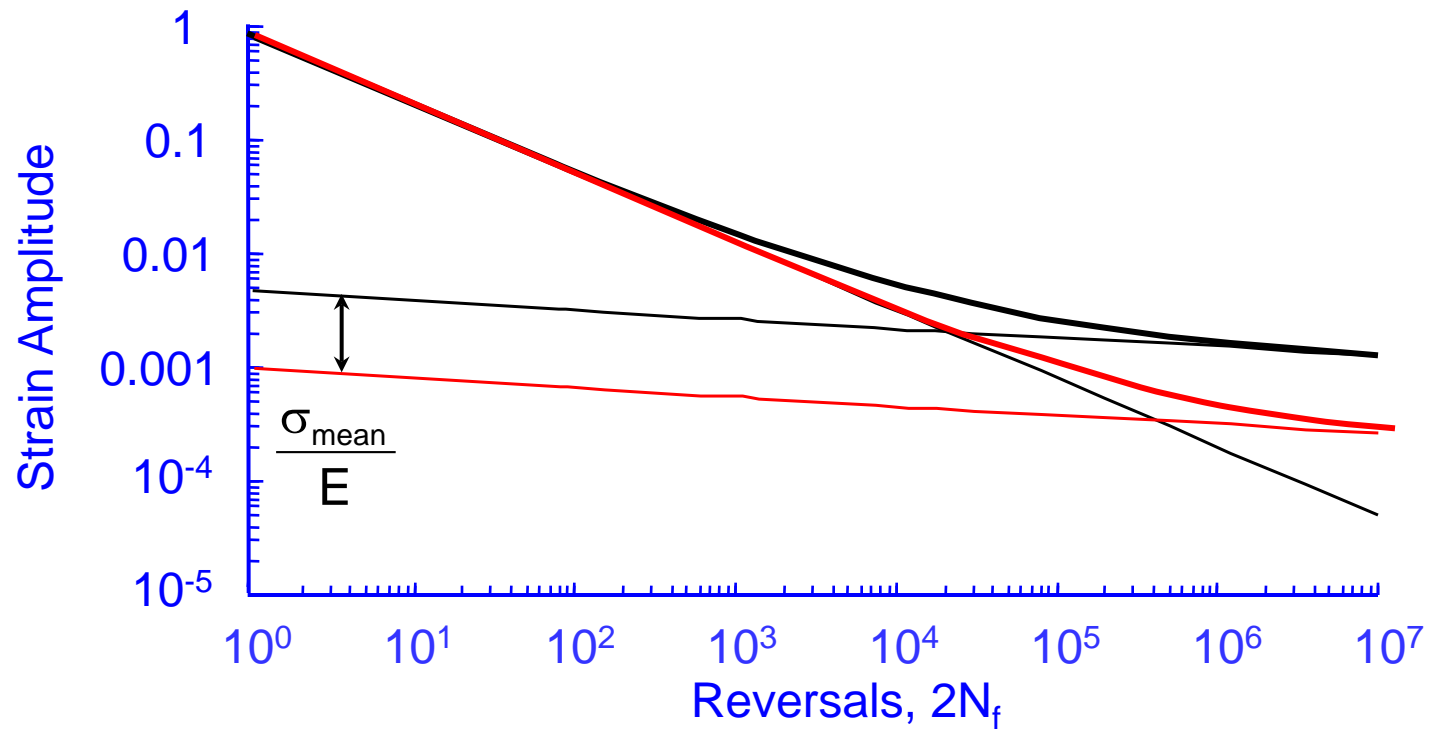

$$\frac{\Delta \varepsilon}{2} = \frac{\sigma_f' - \sigma_{\text{mean}}}{E} (2N_f)^b + \varepsilon_f' (2N_f)^c$$

# Smith Watson Topper

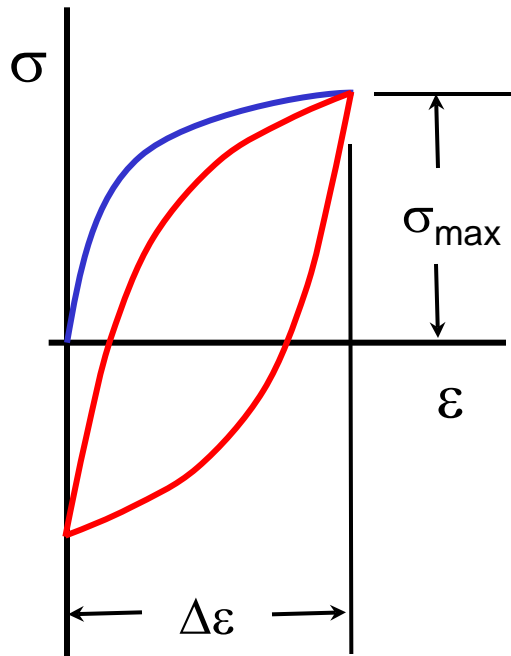

$$\sigma_{\max} \frac{\Delta \varepsilon}{2} = \frac{\sigma_f'^2}{E} (2N_f)^{2b} + \sigma_f' \varepsilon_f' (2N_f)^{b+c}$$

# Mean Stress Relaxation

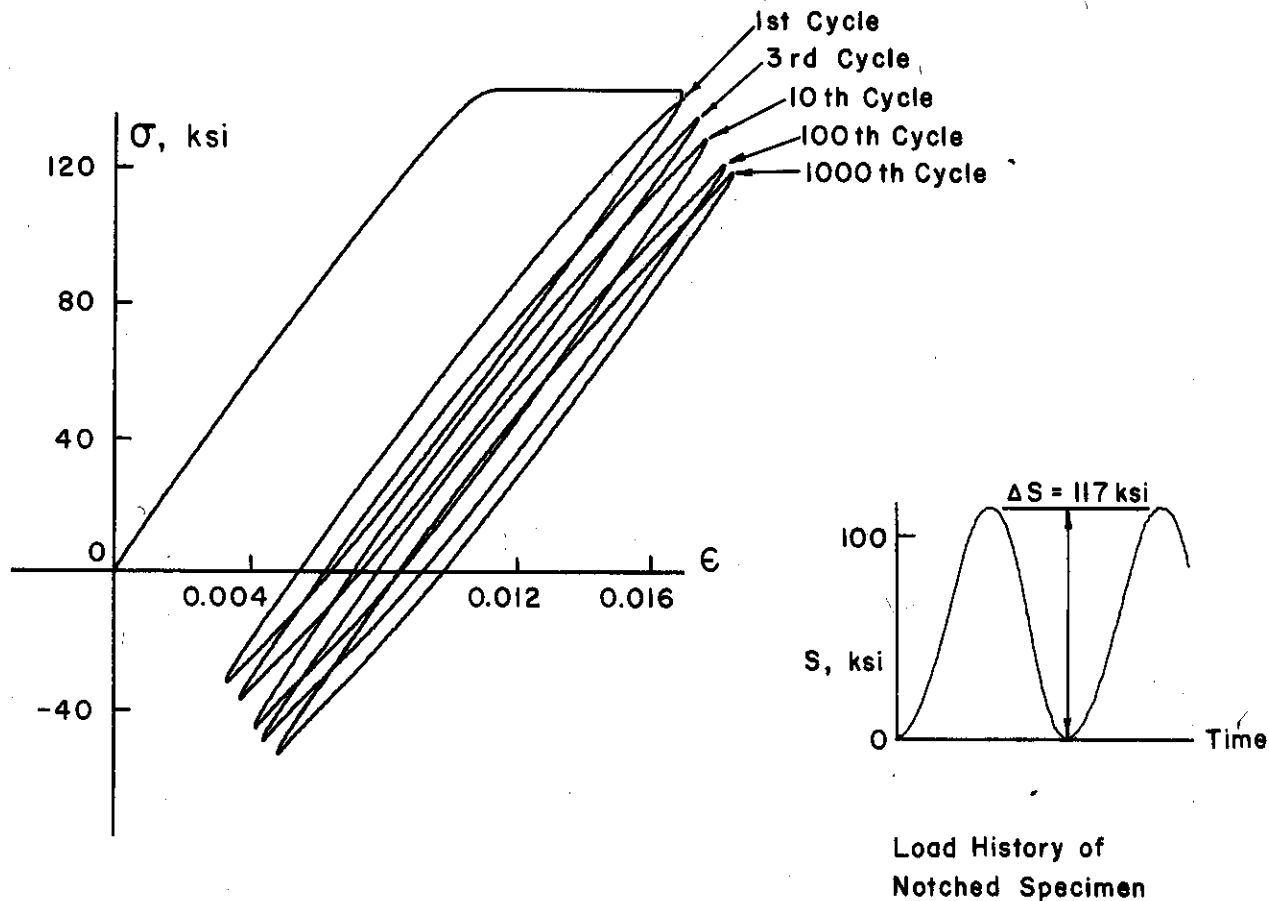
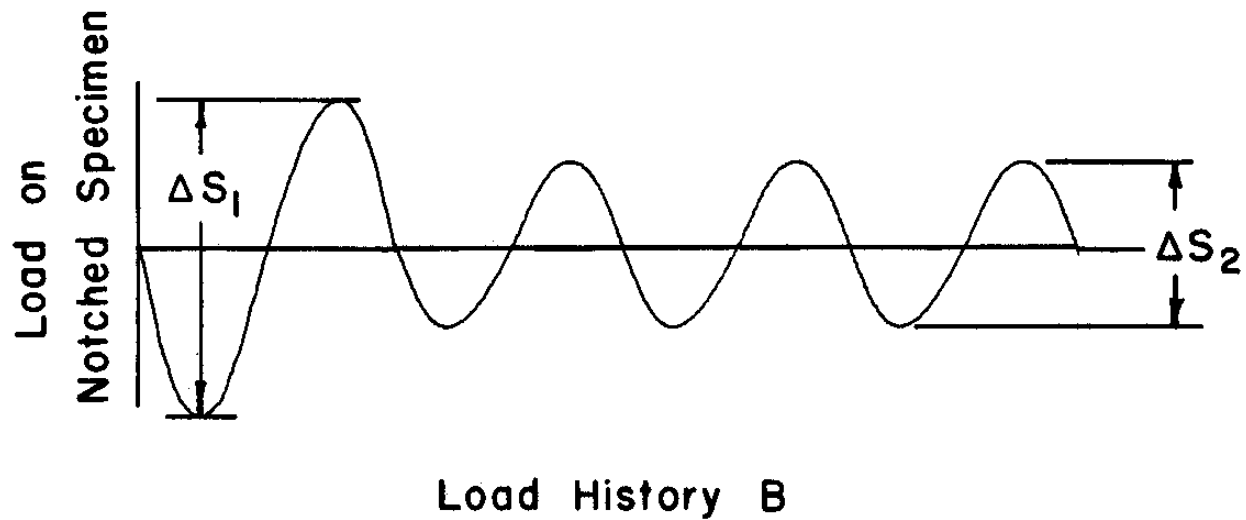
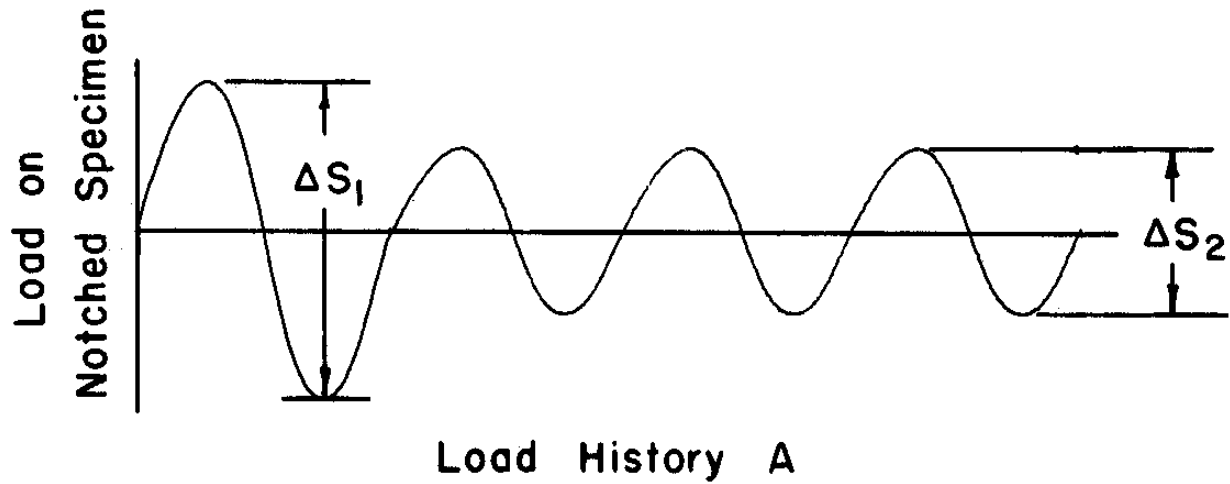

FIG. 7—Cyclic softening and relaxation of mean stress under Neuber control (Ti-8Al-1Mo-IV,  $K_t = 1.75$ ).

Stadnick and Morrow, "Techniques for Smooth Specimen Simulation of Fatigue Behavior of Notched Members"  
ASTM STP 515, 1972, 229-252



# Loading Histories



# Test Results

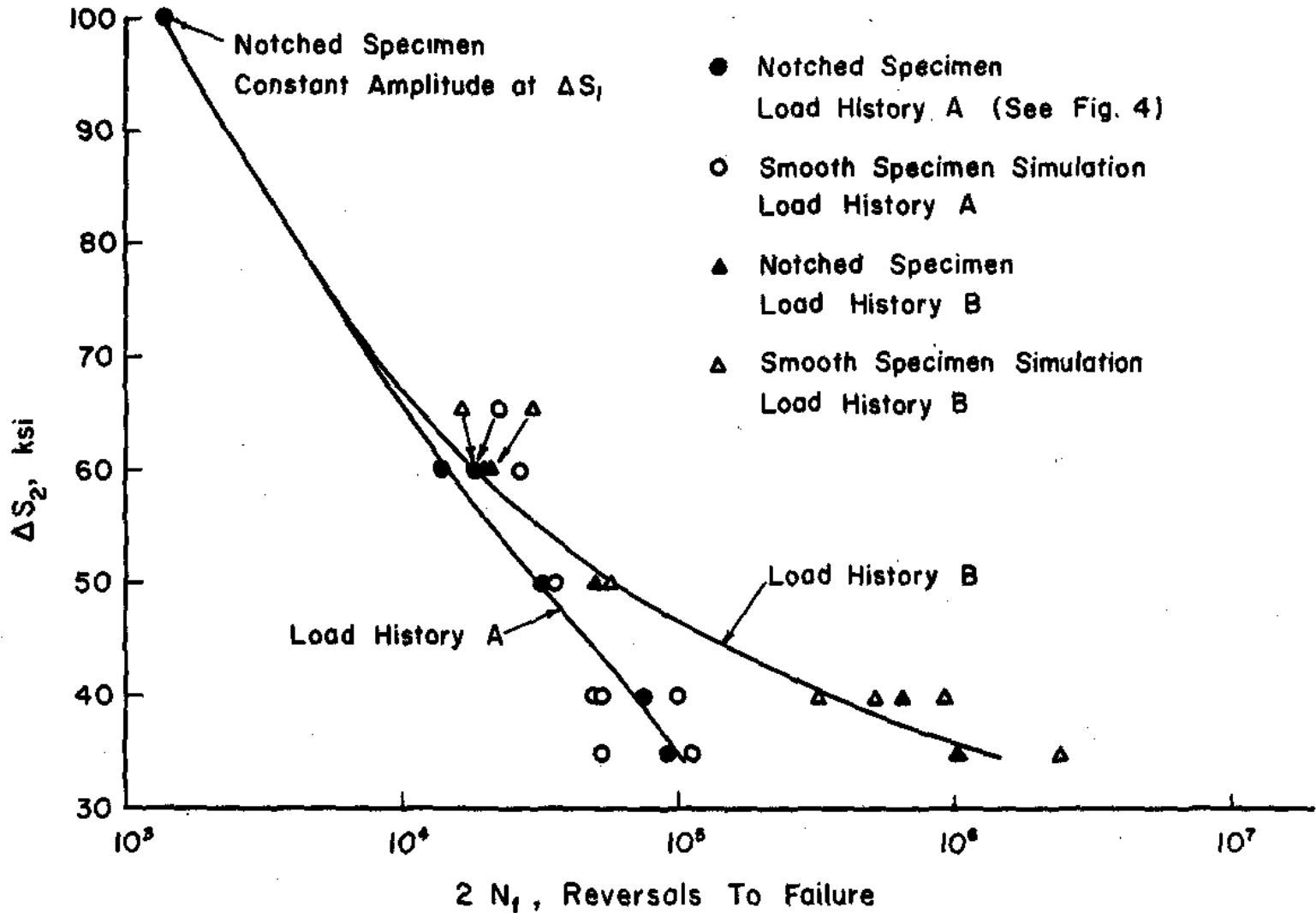

# Crack Growth Physics

Maximum load

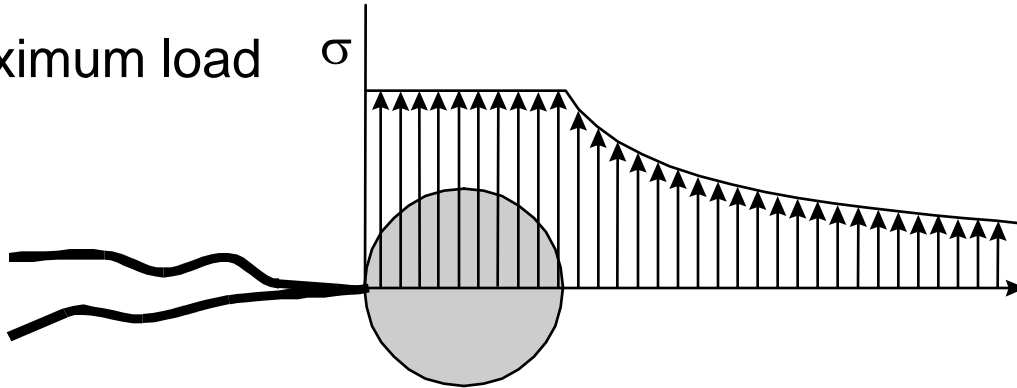

Minimum load

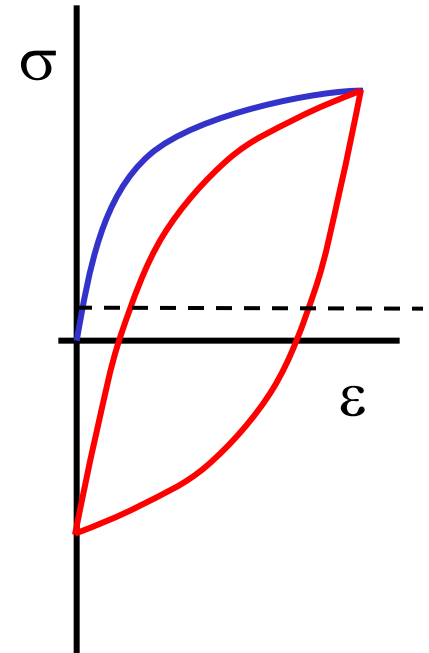
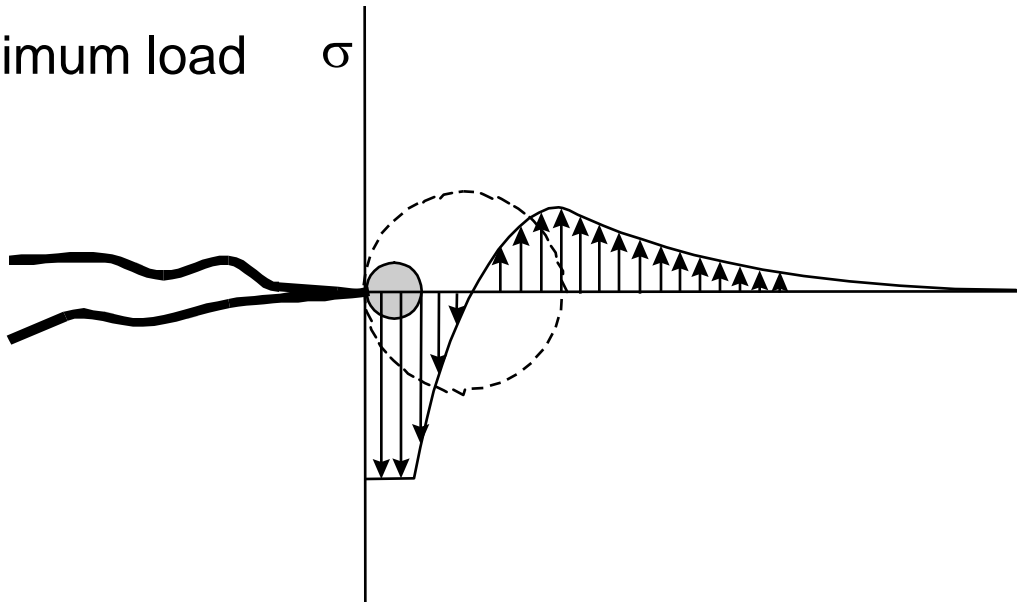

Mean stresses in plastic zone are small

# Mean Stress Effects

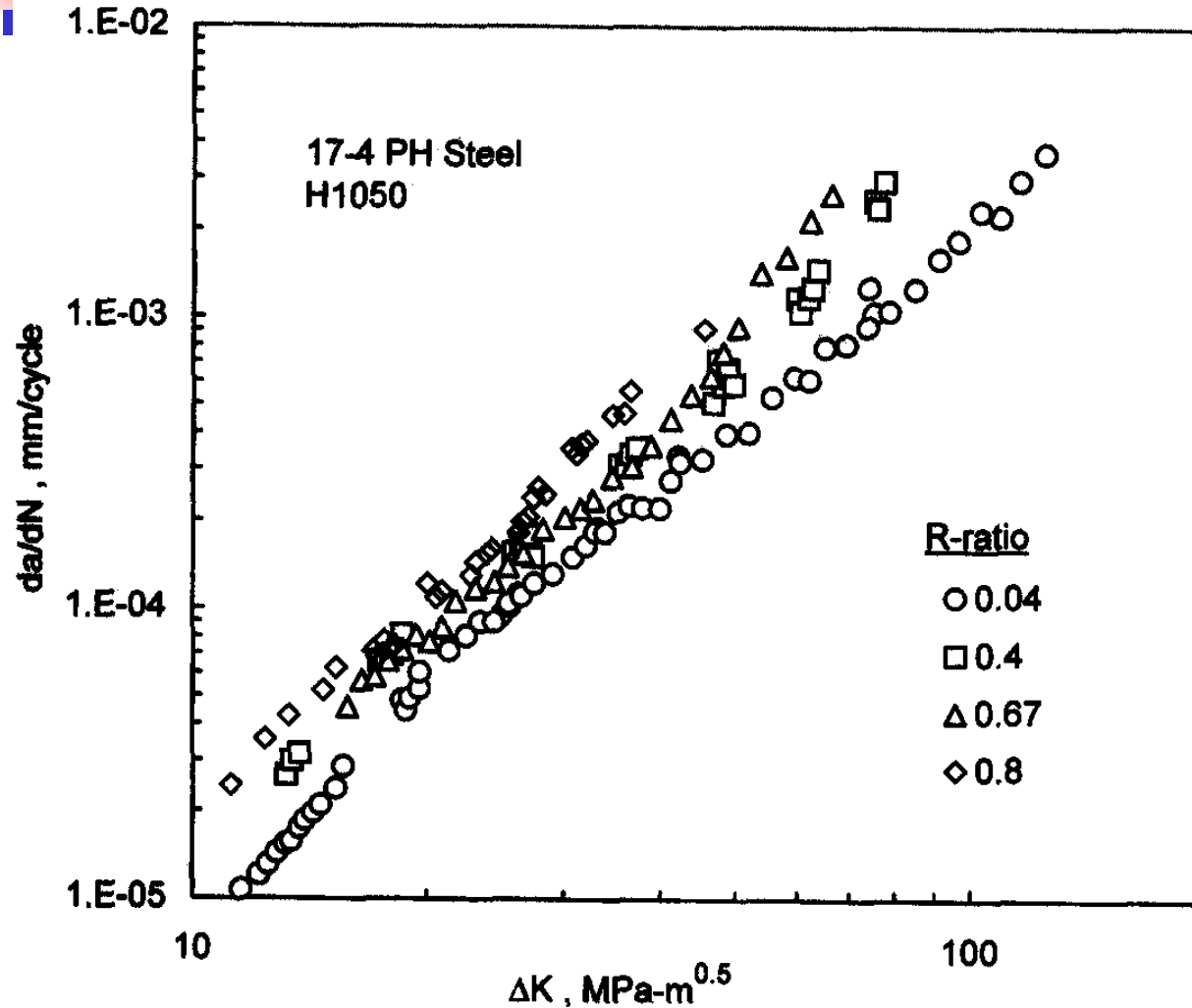

$$\frac{da}{dN} = \frac{C \Delta K^m}{(1-R)^\gamma}$$

$$0 < \gamma < 0.5$$

From: Dowling and Thangjitham, An Overview and Discussion of Basic Methodology for Fatigue, ASTM STP 1389, 2000, 3-38



# Compression

---

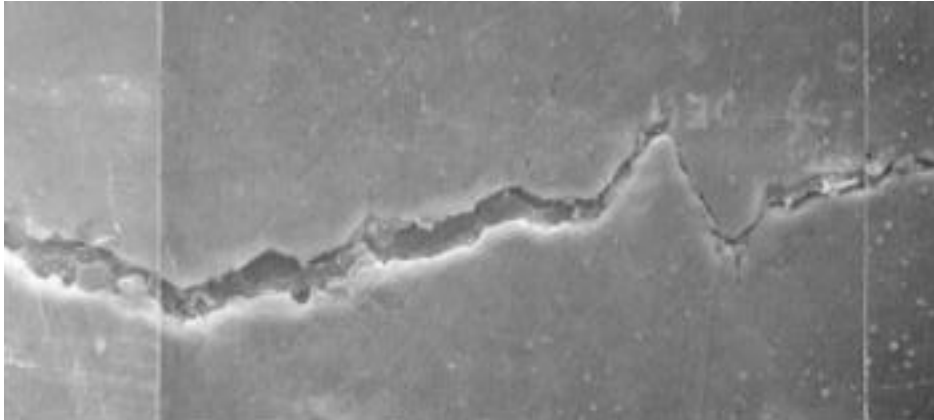

Crack open



Crack closed

# Compressive Stresses

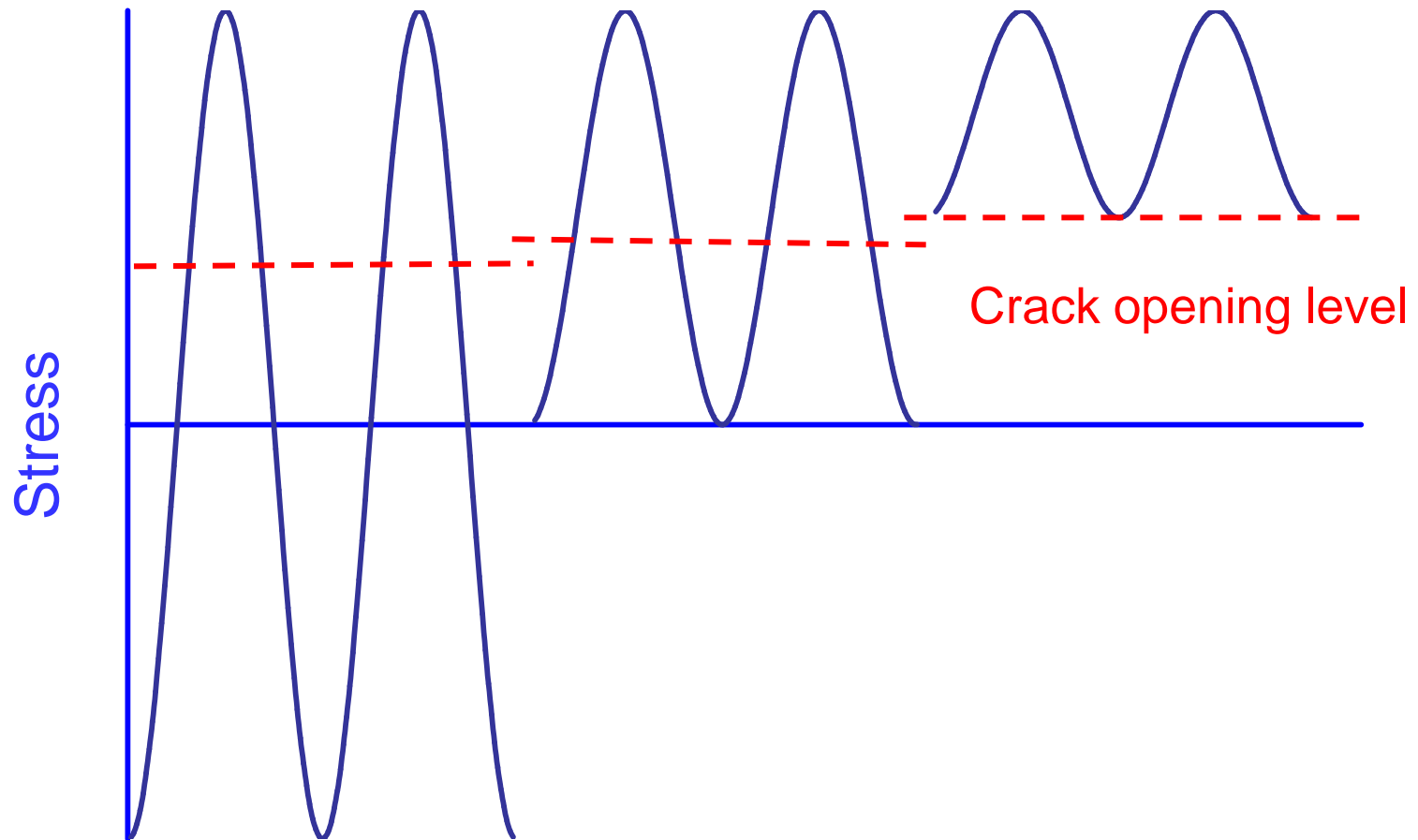

Compressive stresses are not very damaging in crack growth



# Sources of Mean/Residual Stress

---

- Loading History
- Fabrication
- Shot Peening
- Heat Treating

# Loading History

Tension overloads produce favorable compressive residual stress

Compressive overloads produce unfavorable tensile residual stress

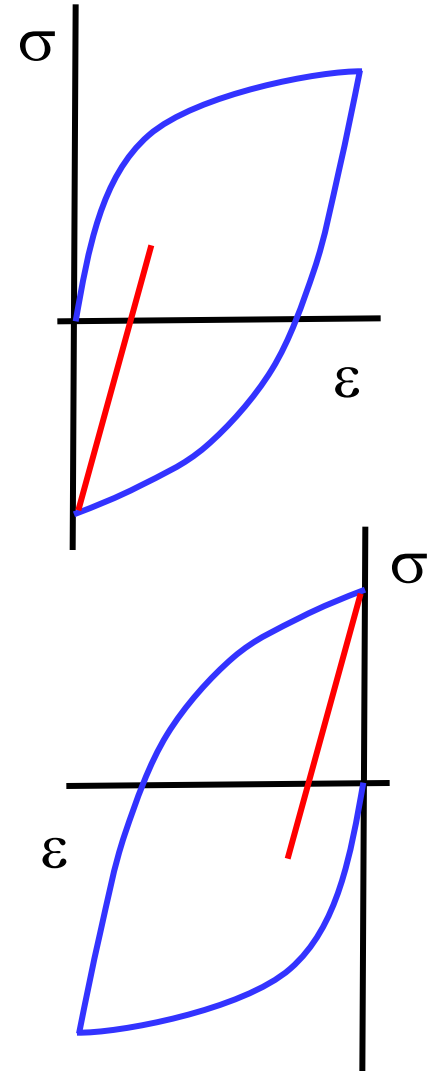



# Fabrication

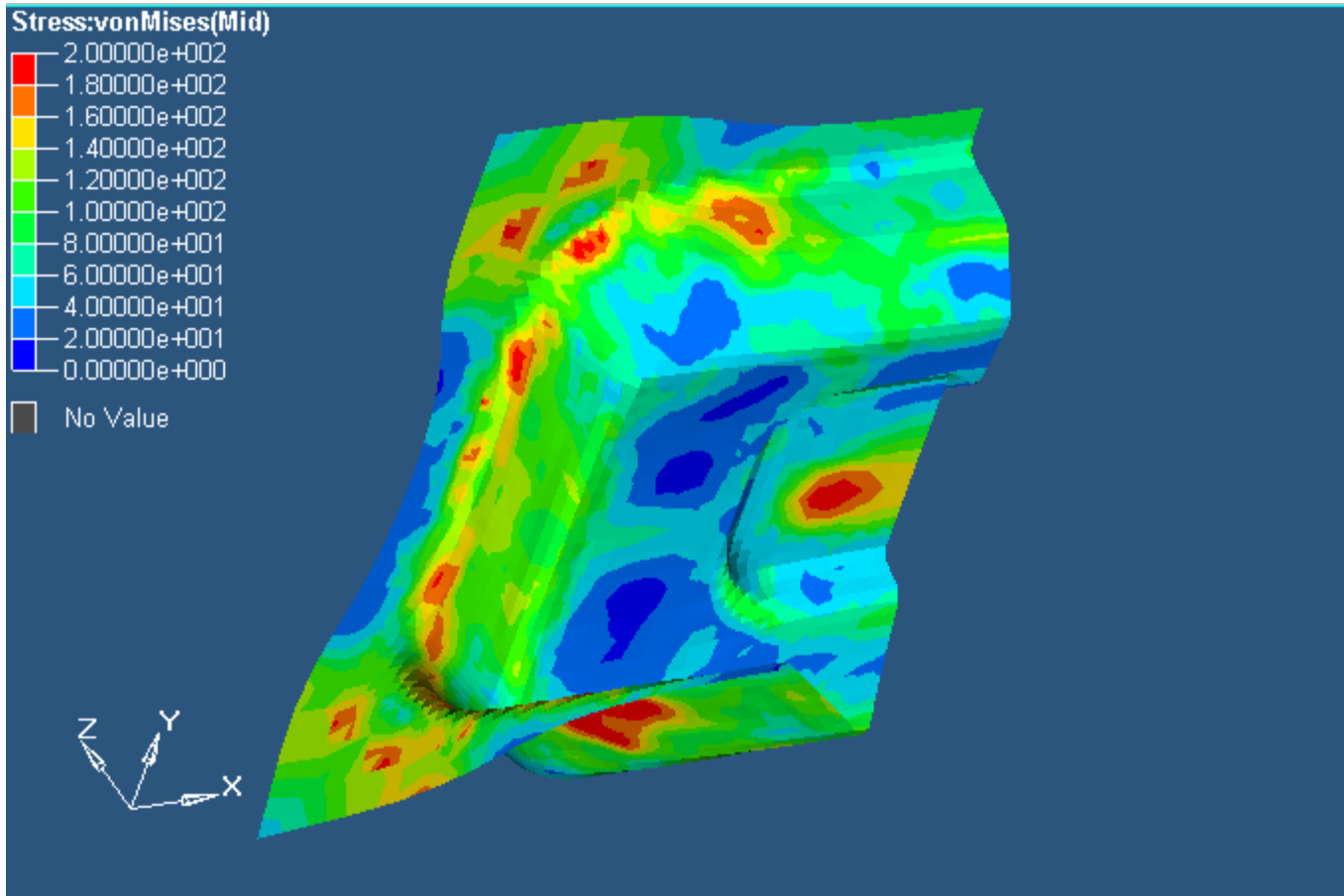

# Cold Expansion

## 1965 Basic Cx process conceptualized (Boeing)

The split sleeve is slipped onto the mandrel, which is attached to the hydraulic puller unit.

The mandrel and sleeve are inserted into the hole with the nosecap held firmly against the workpiece.

When the puller is activated, the mandrel is drawn through the sleeve radially expanding the hole.

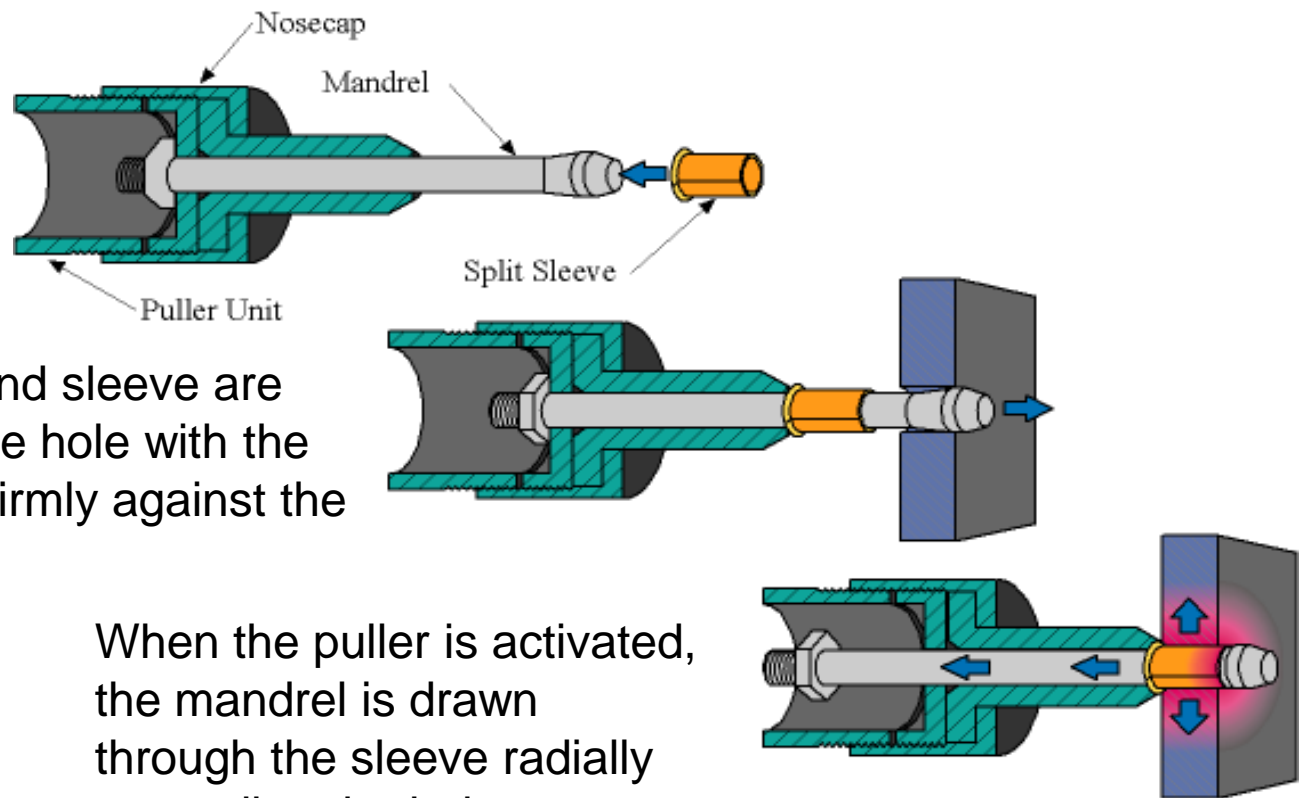

Courtesy of Fatigue Technology Inc.

# Theory of Cold Expansion

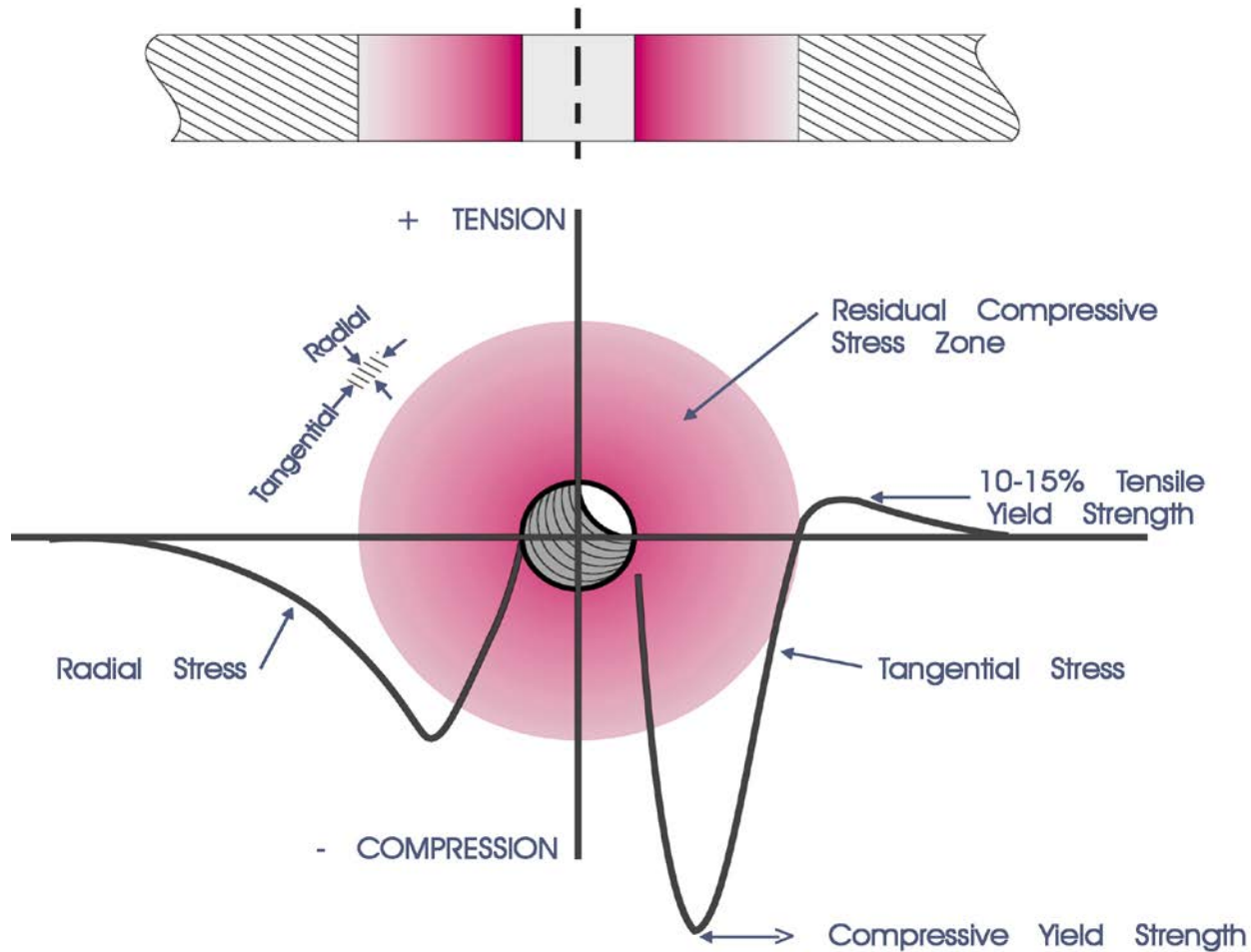

Courtesy of Fatigue Technology Inc.

# Fatigue Life Improvement

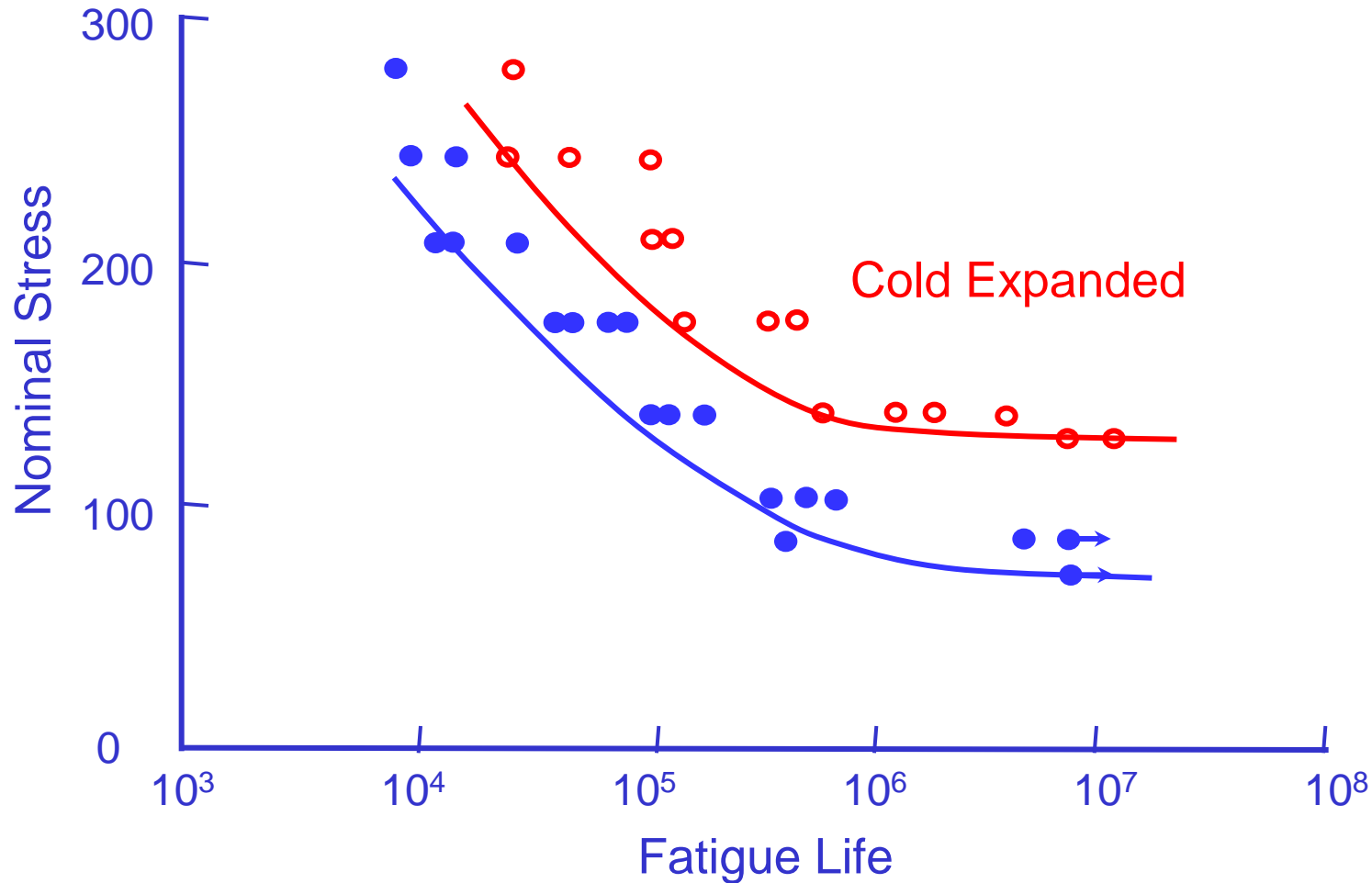

Courtesy of Fatigue Technology Inc.

# Shot Peening

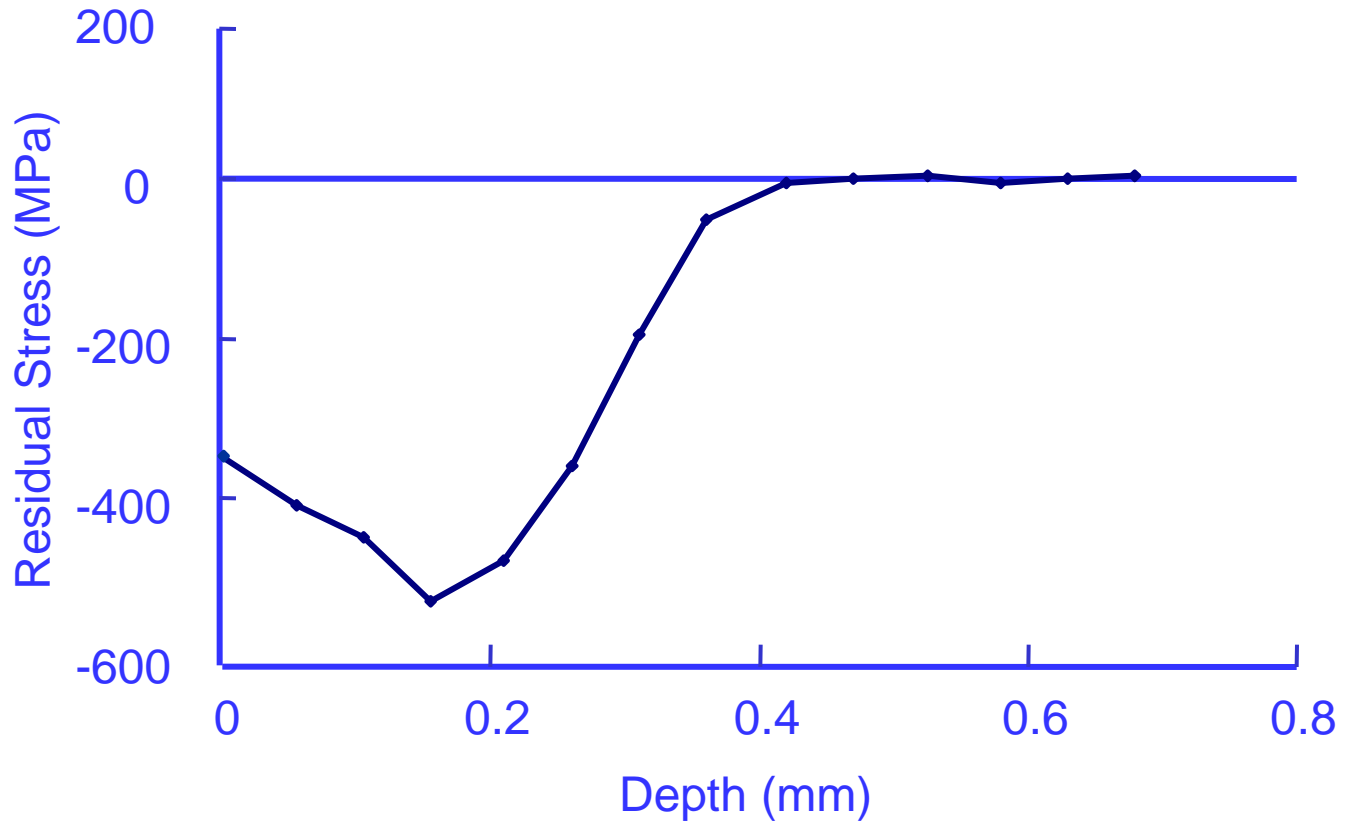
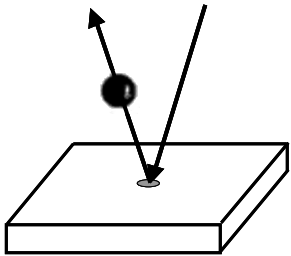

Residual stress in a shot peened leaf spring

# Shot Peening Results

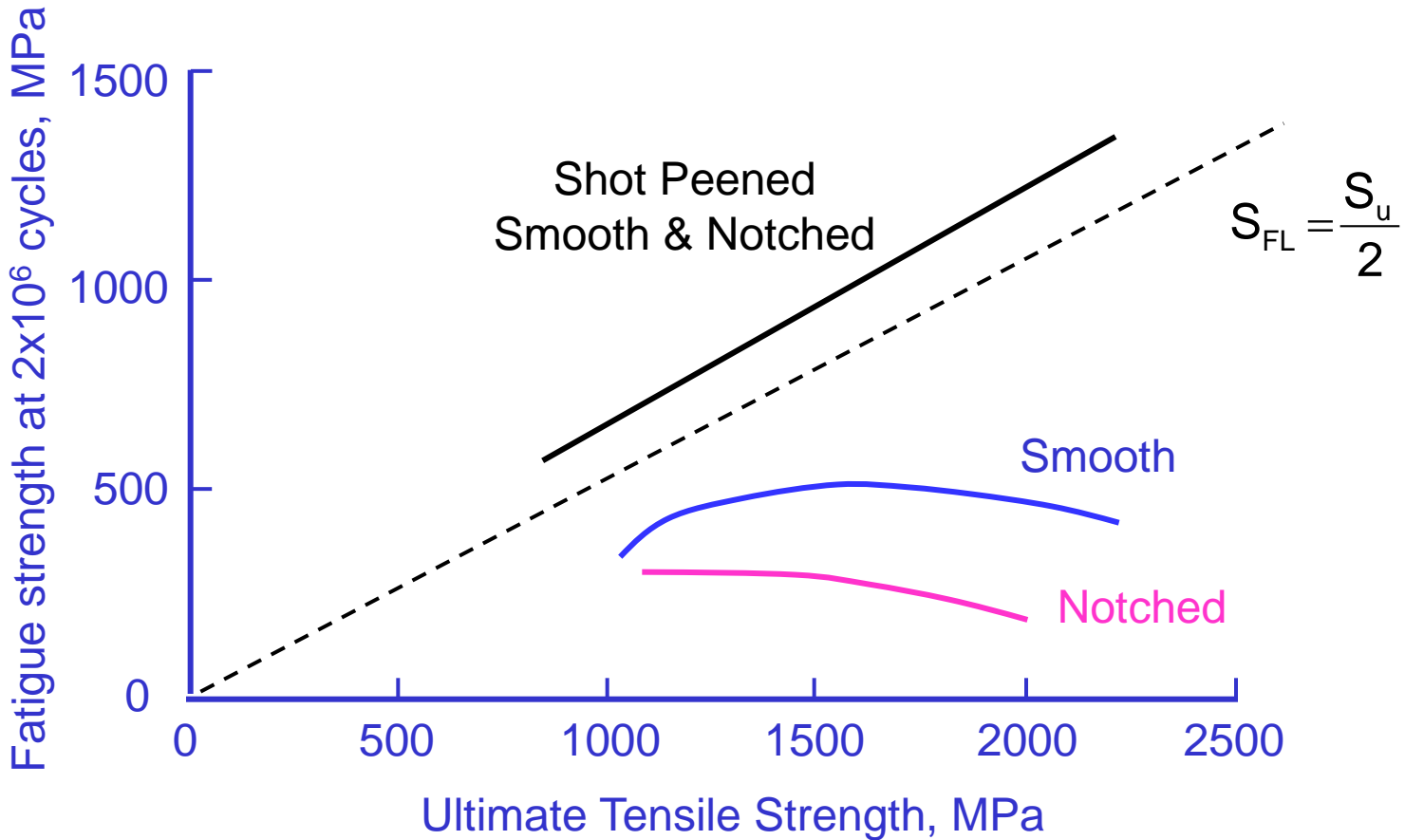

www.metalimprovement.com

# Heat Treating

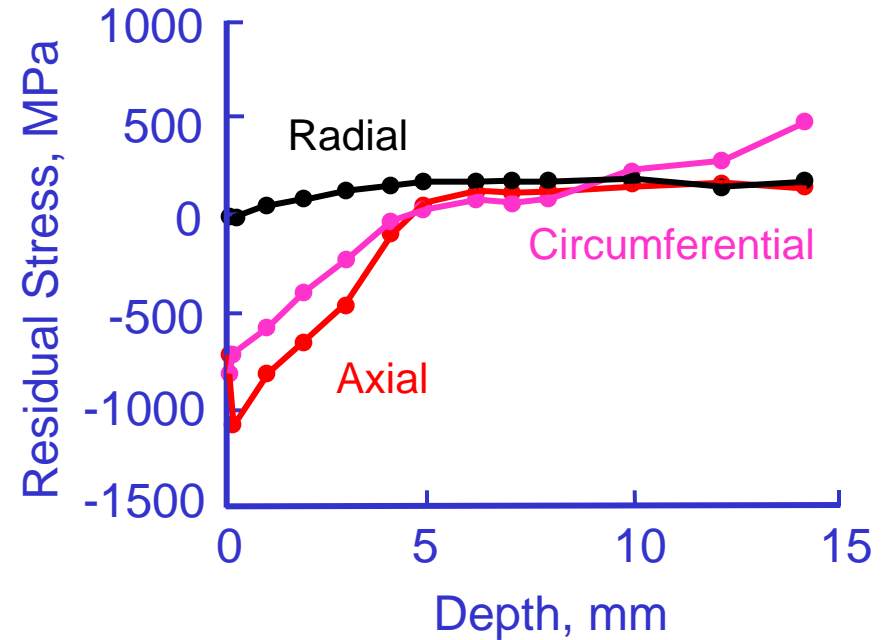
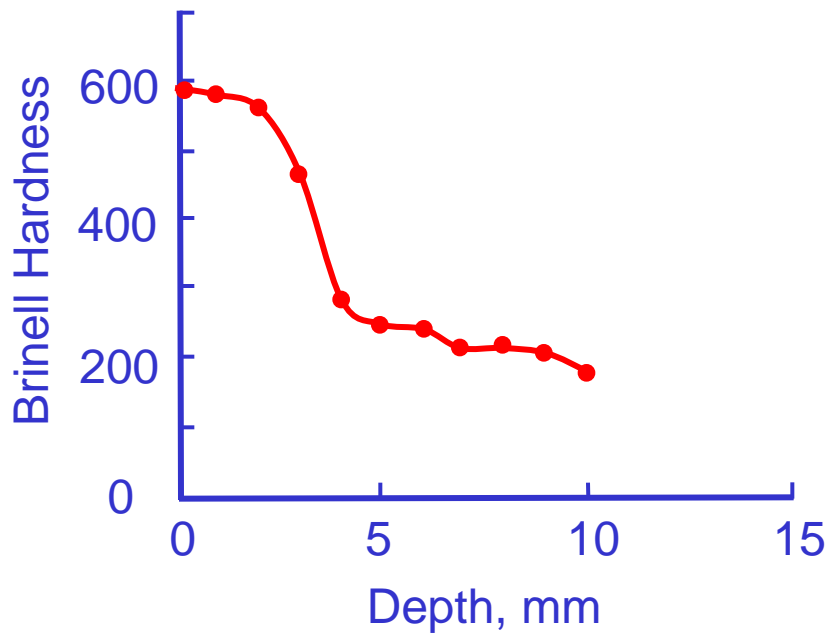

50 mm diameter induction hardened 1045 steel shaft



# Things Worth Remembering

---

- Local mean stress rather than the nominal mean stress governs the fatigue life
- Mean stress has the greatest effect on crack nucleation





# Factors Influencing Fatigue

---

- Mean Stress
- **Variable Amplitude**
- Stress Concentrations
- Surface Finish



# Variable Amplitude Loading

---

How to you identify cycles ?

How do you assess fatigue damage for a cycle ?

# Rainflow Cycle Counting



图 6. 重疊波尖頭值 $\sigma$ 系列值.



图 7(a) 重疊波底層曲線

图 7(b) 双峰波底層曲線

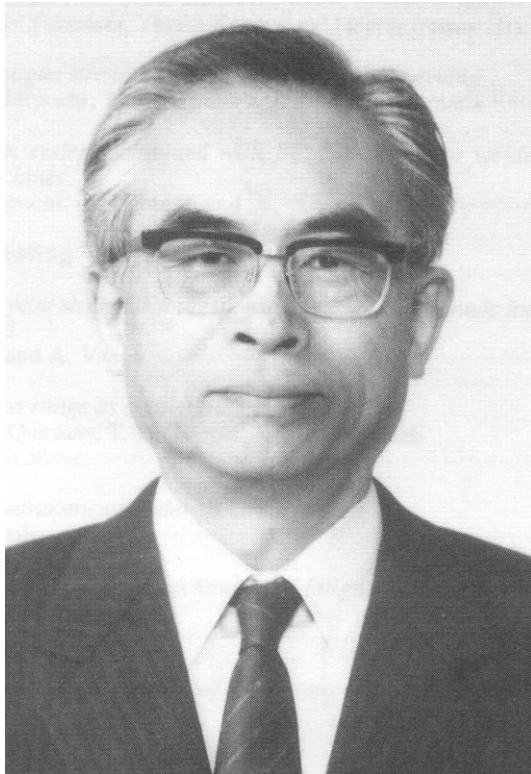
What could be more basic than learning to count correctly?

Matsuishi and Endo (1968) Fatigue of Metals Subjected to Varying Stress – Fatigue Lives Under Random Loading, Proceedings of the Kyushu District Meeting, JSME, 37-40

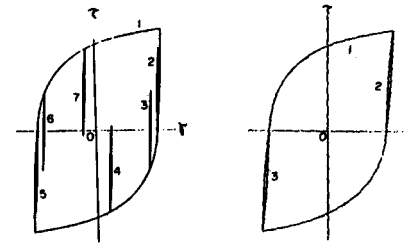
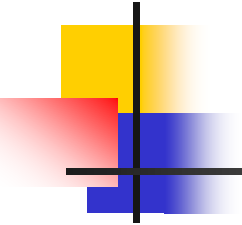

# Rainflow

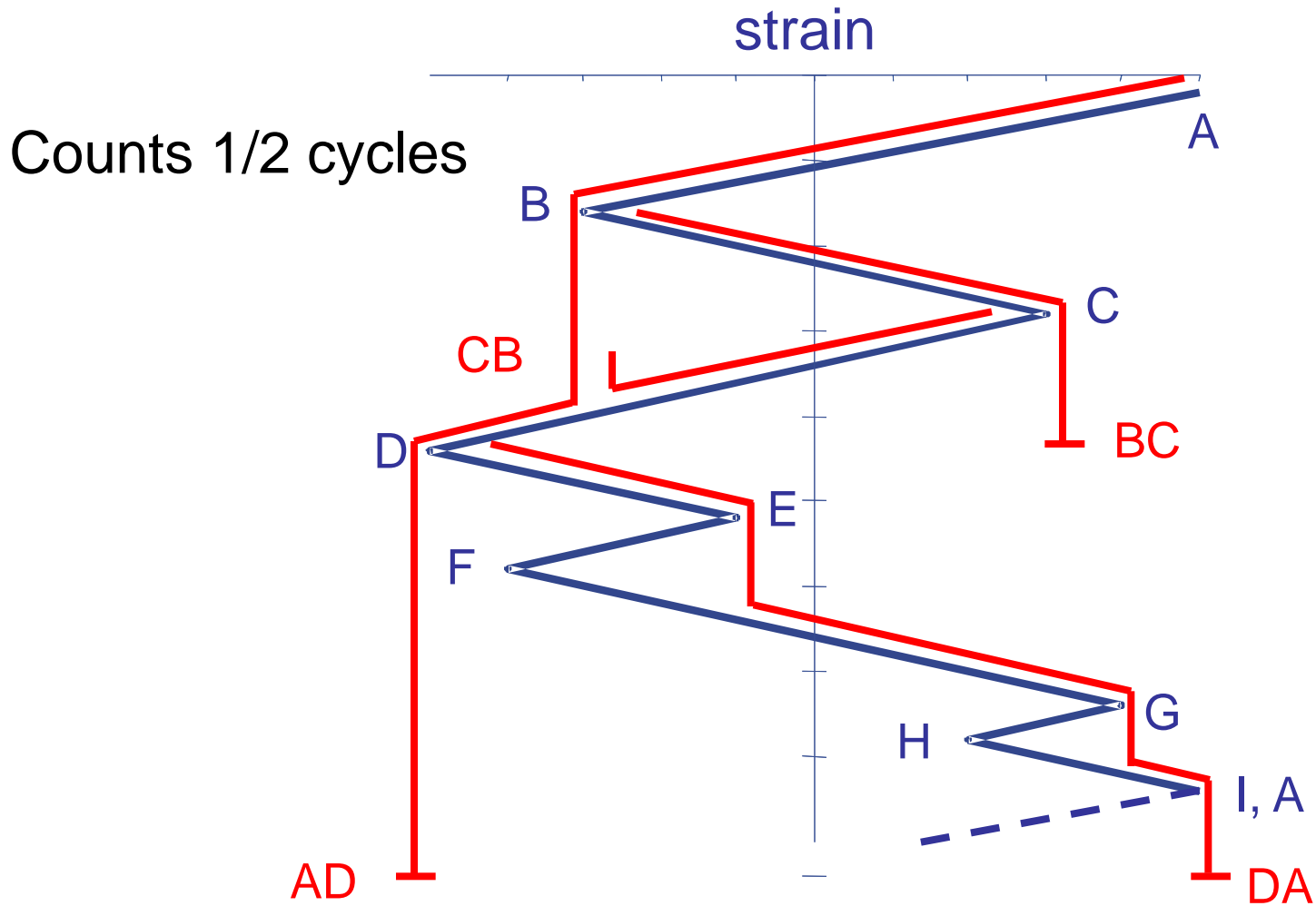

# Rainflow and Hysteresis

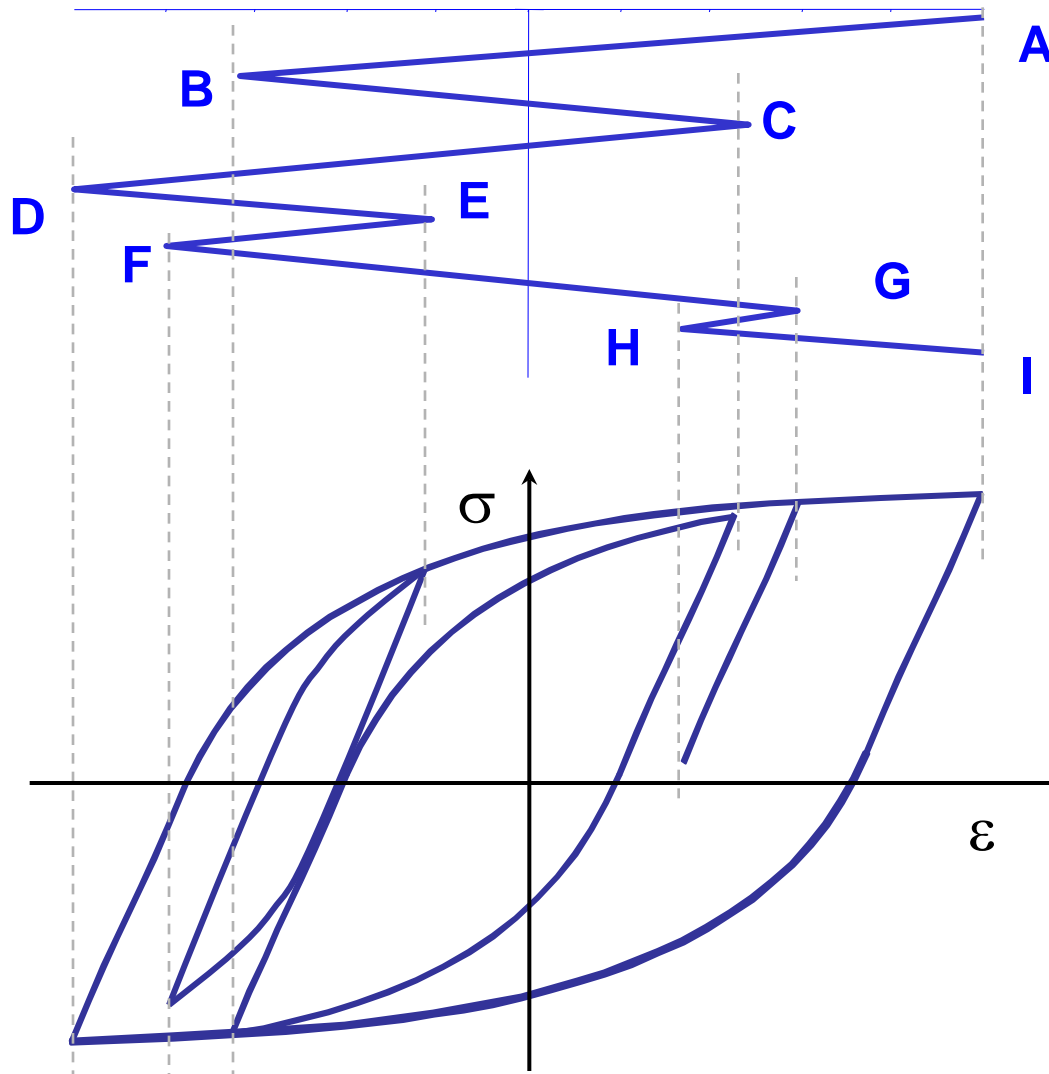

# Cumulative Damage

High - Low

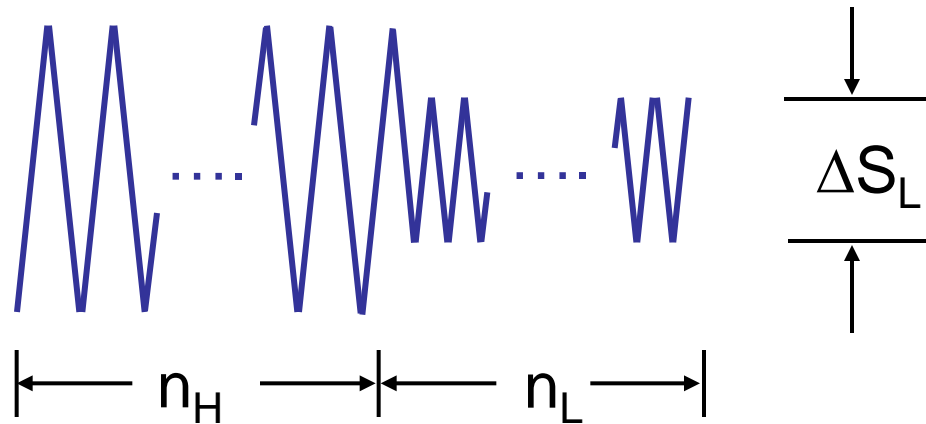

Low - High

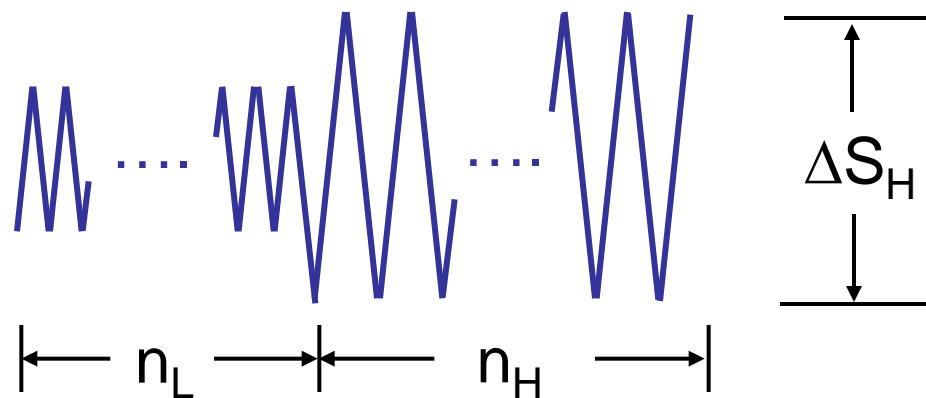

# Linear Damage

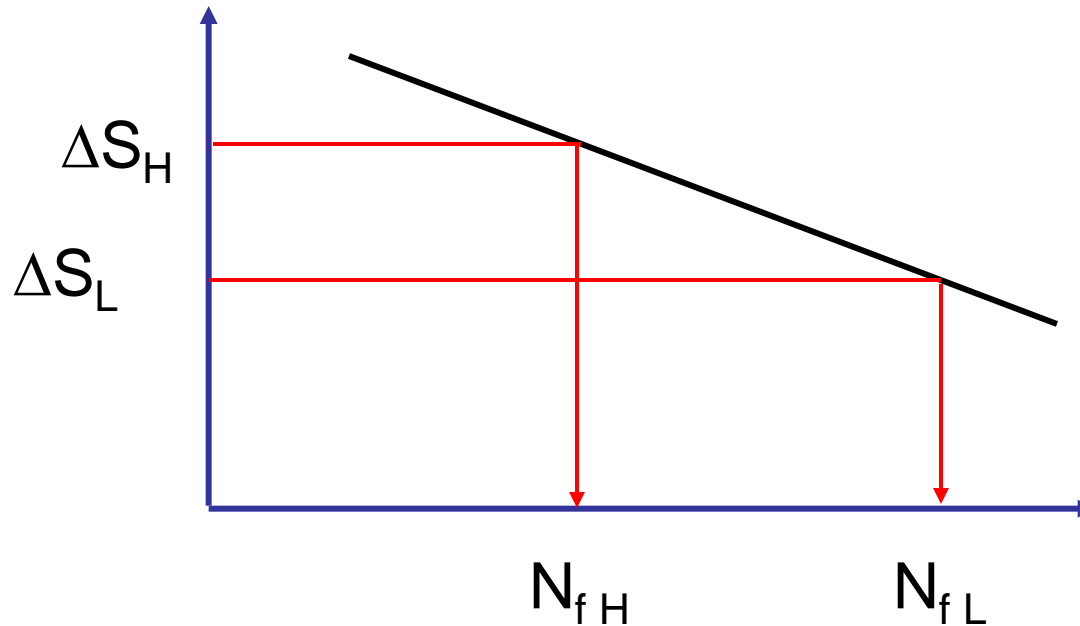

Miner's Rule:

$$\text{Damage} = \sum \frac{n}{N_F} = \frac{n_H}{N_{fH}} + \frac{n_L}{N_{fL}}$$

# Nonlinear Damage

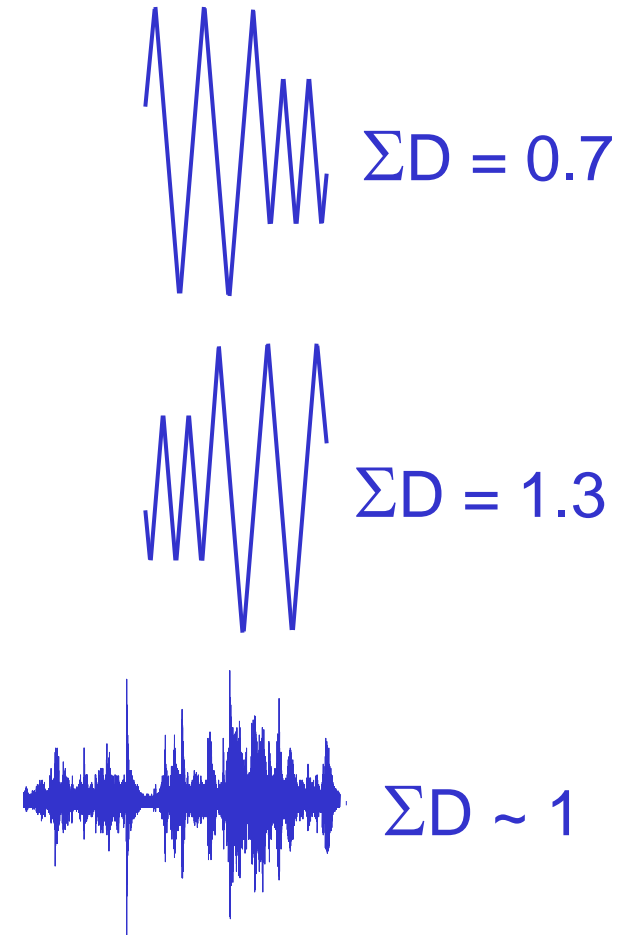
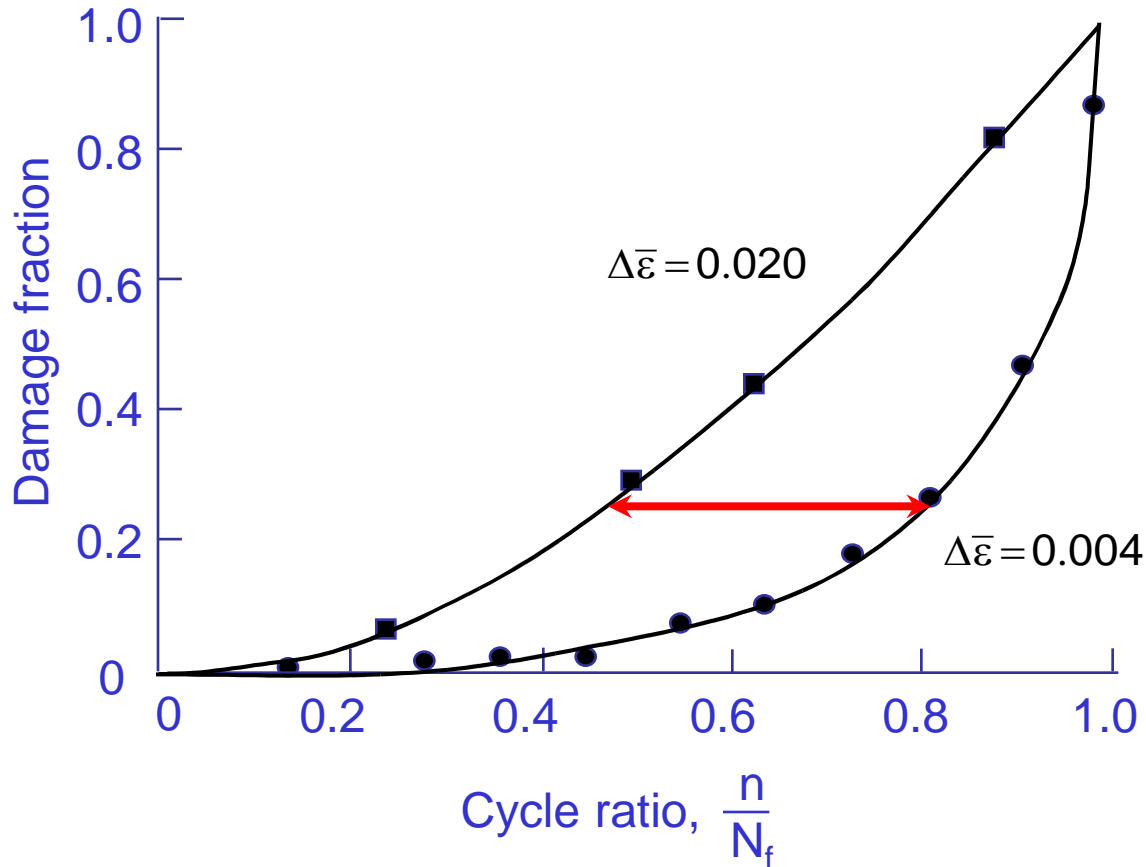



# Periodic Overload Results

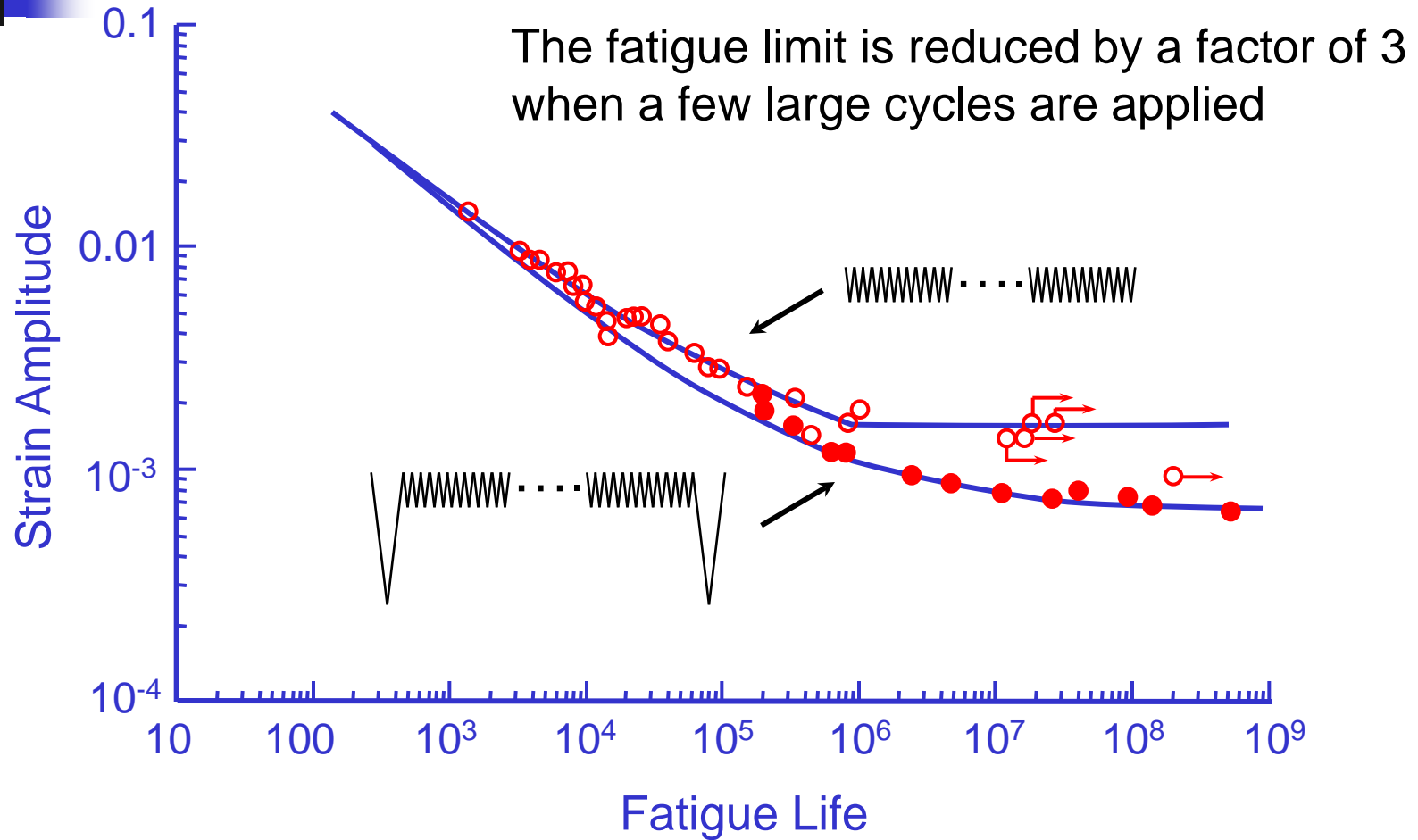

Bonnen and Topper, "The Effects of Periodic Overloads on Biaxial Fatigue of Normalized SAE 1045 Steel"  
ASTM STP 1387, 2000, 213-231

# Fatigue Damage Calculations

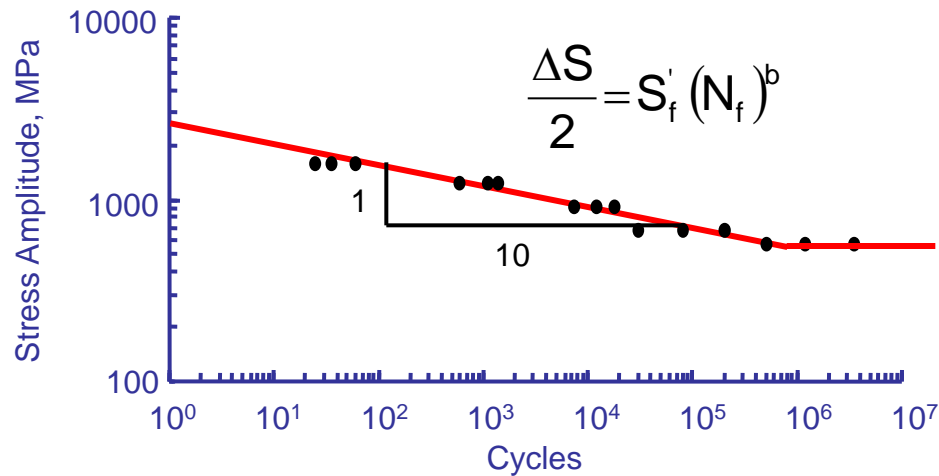

$$N_f = \left( \frac{\Delta S}{2 S'_f} \right)^{\frac{1}{b}}$$

$$\text{Damage} \propto \Delta S^{10}$$

# Crack Growth Data

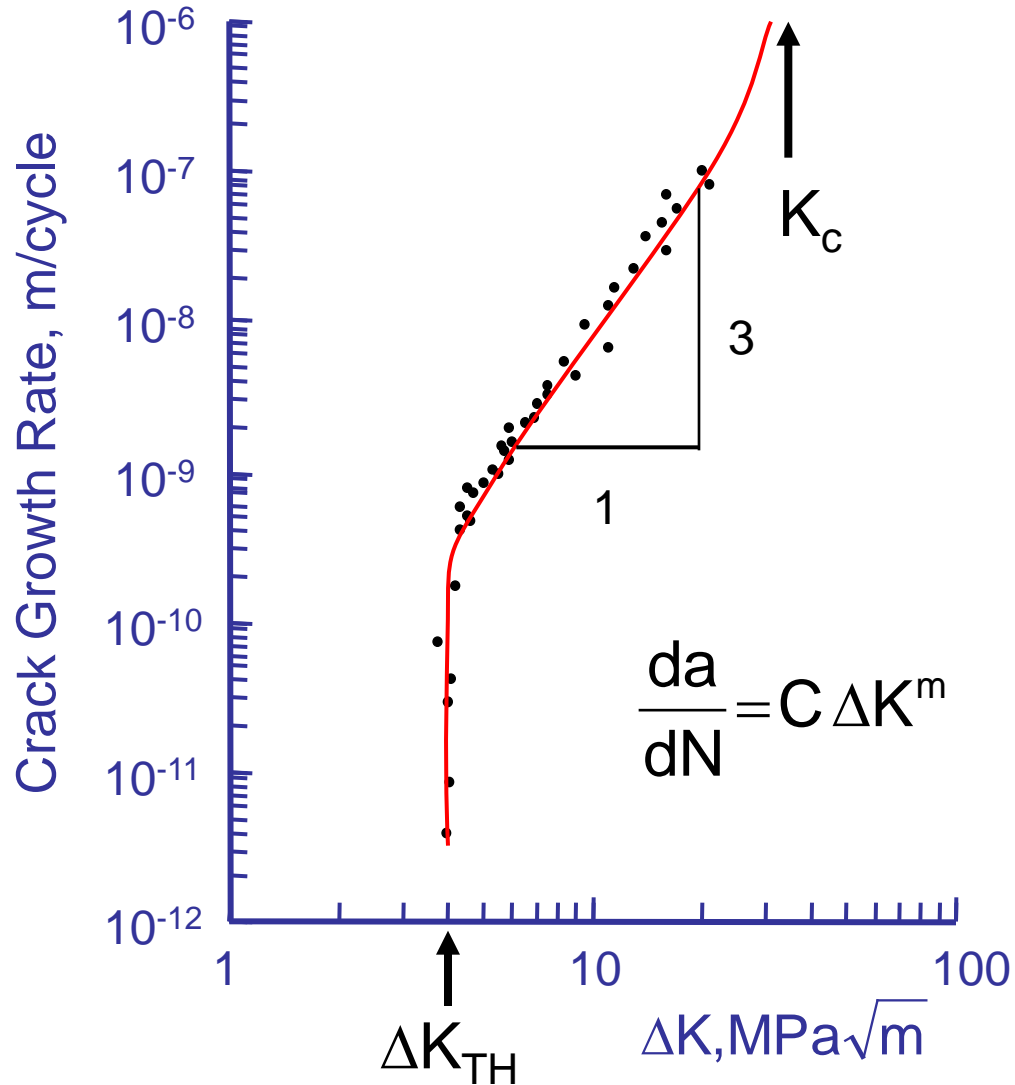

# Crack Growth Data

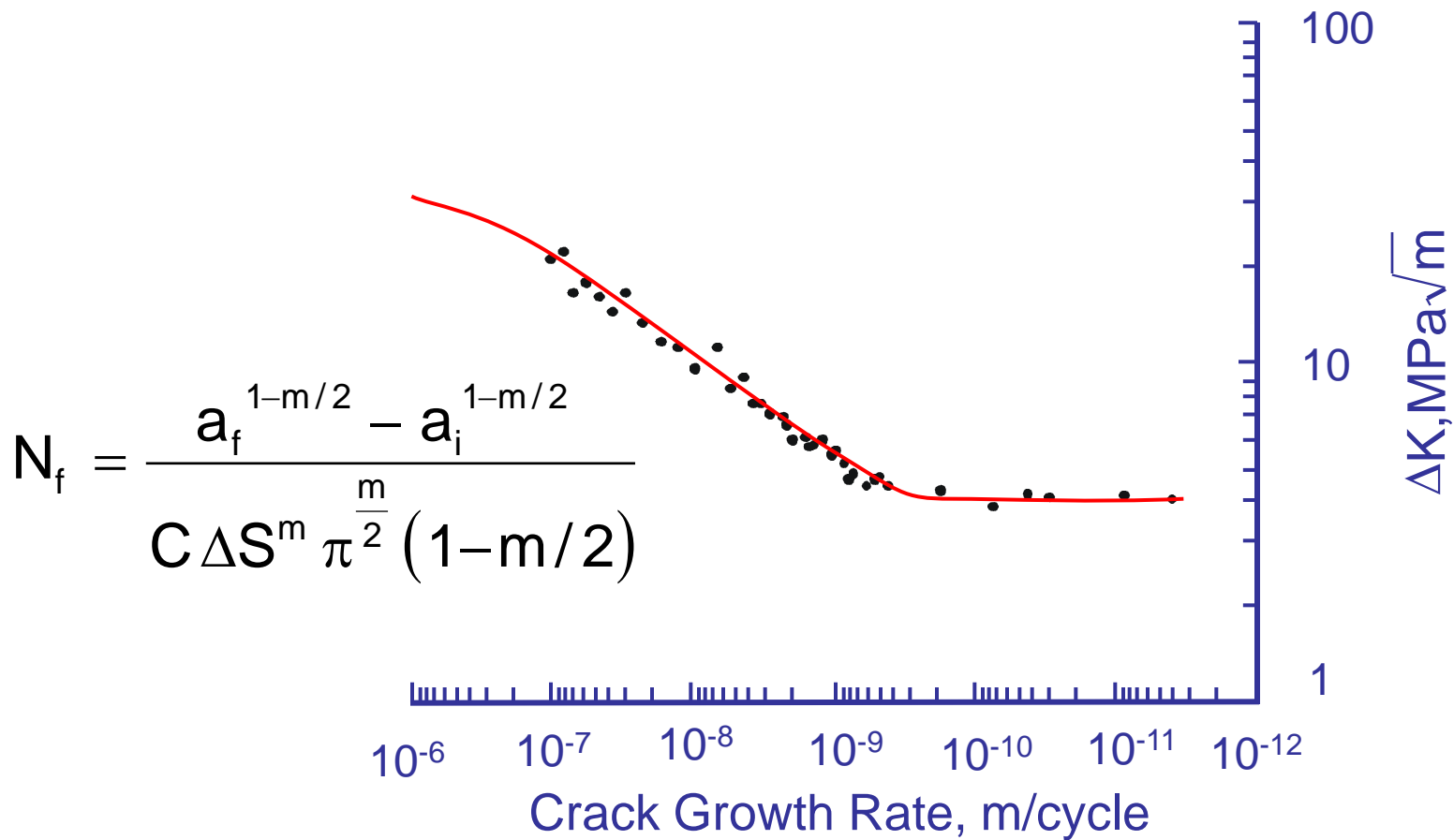

$$N_f = \frac{a_f^{1-m/2} - a_i^{1-m/2}}{C \Delta S^m \pi^{\frac{m}{2}} (1-m/2)}$$

$$\text{Damage} \propto \Delta S^3$$



# Multiple Choice

---

Which cycles do the most fatigue damage ?

- (a) a few large cycles
- (b) a moderate number of intermediate cycles
- (c) a large number of small cycles

# Fatigue Data

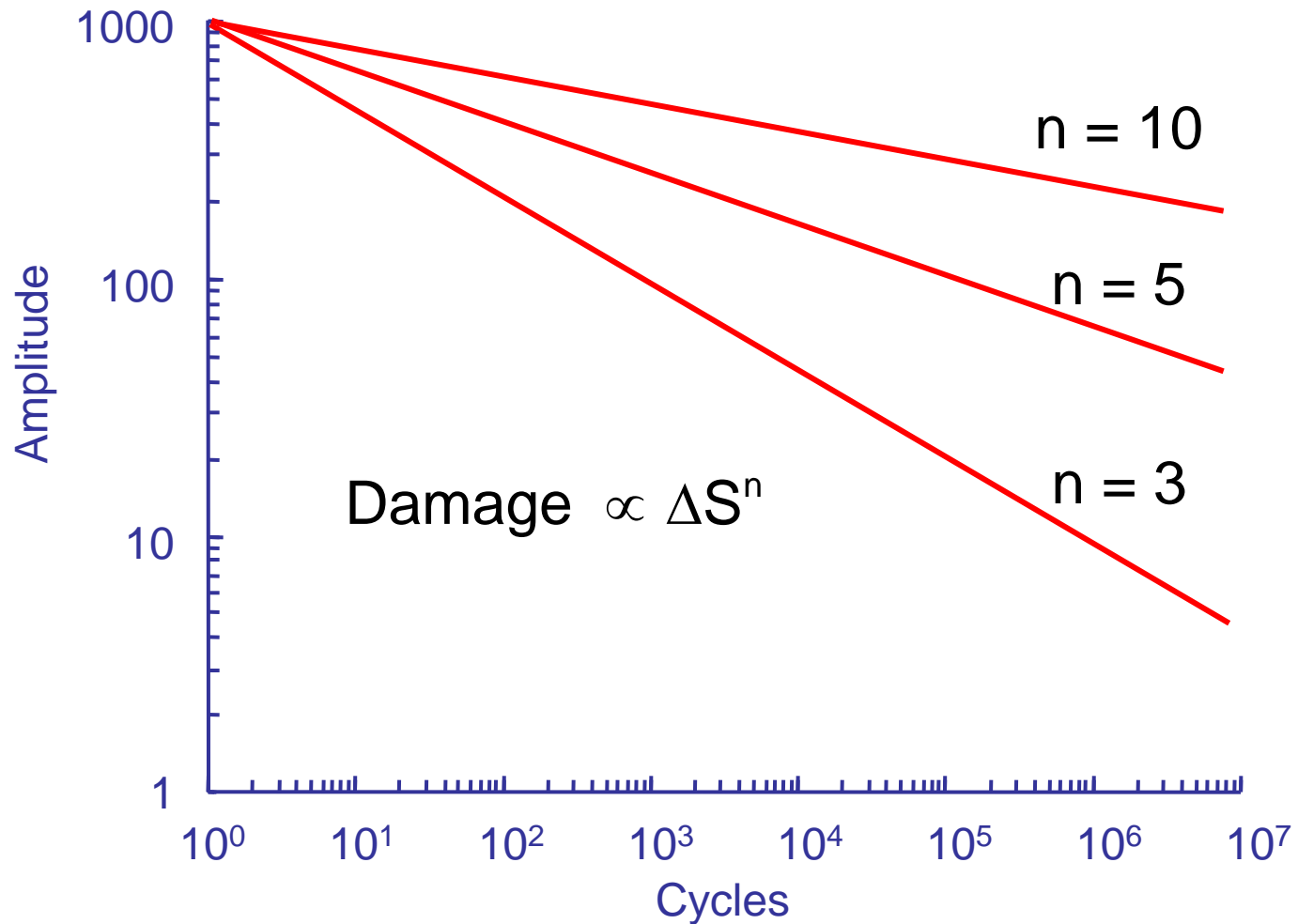

# Loading History

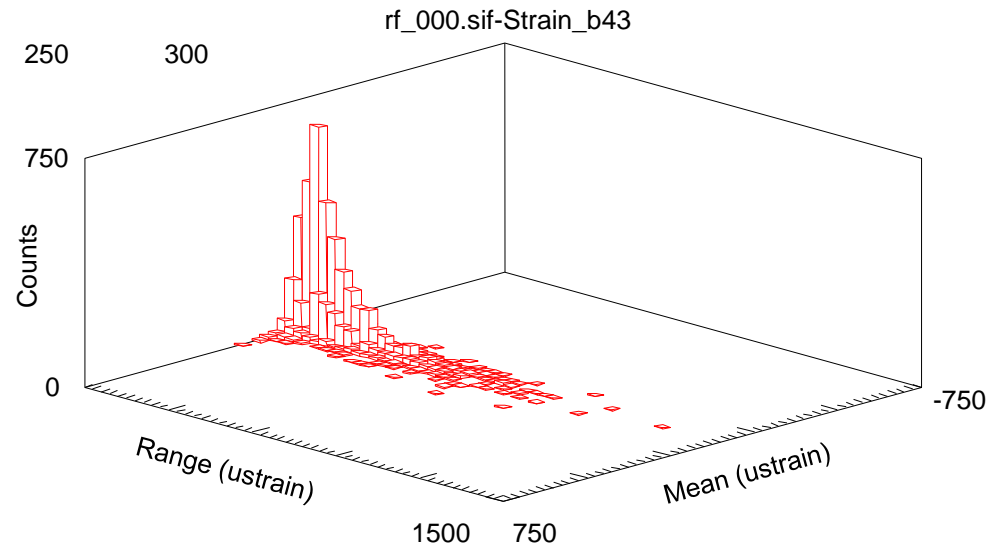
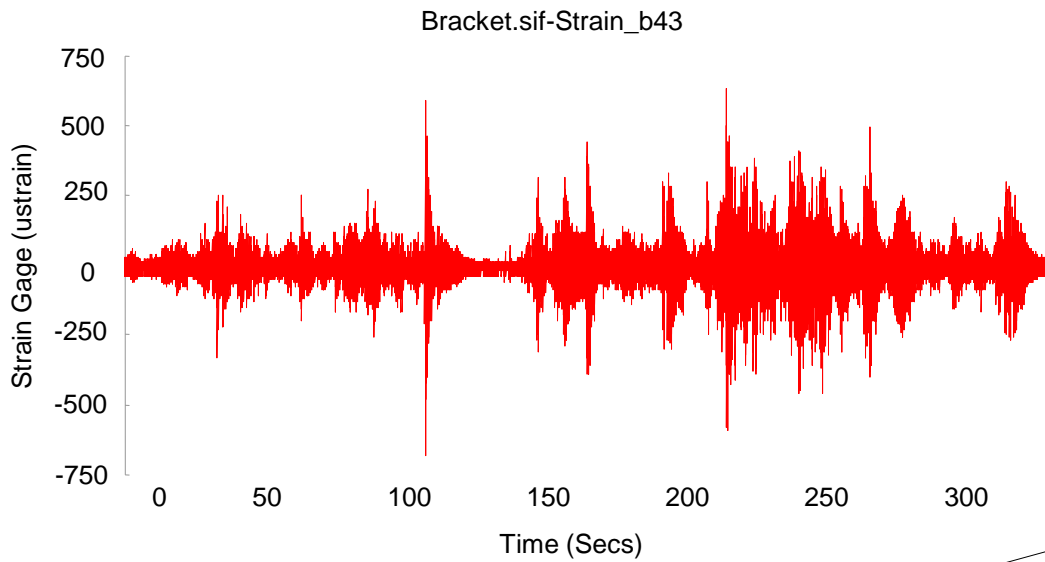

# Slope = 3

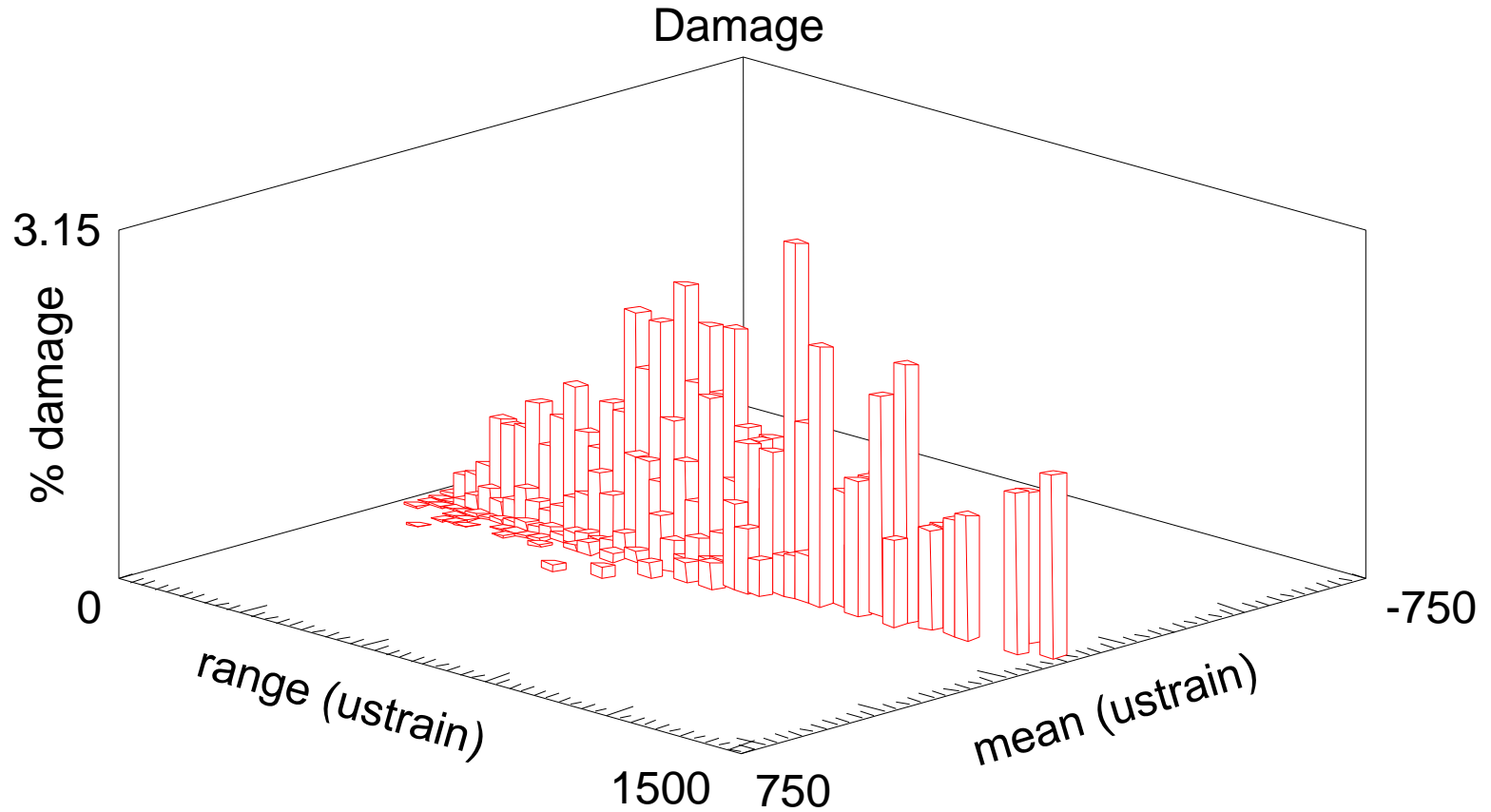



# Slope = 5

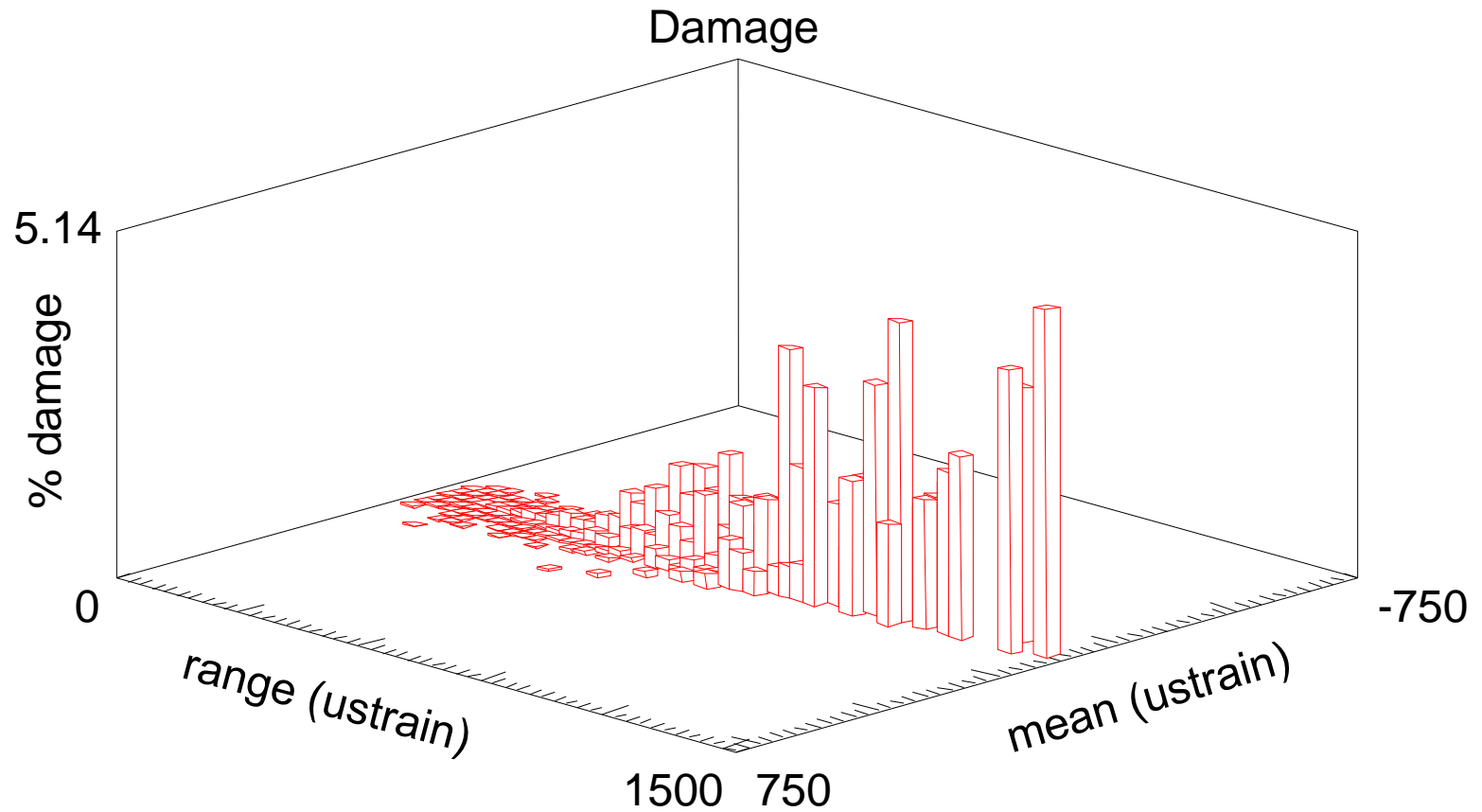

# Slope = 10

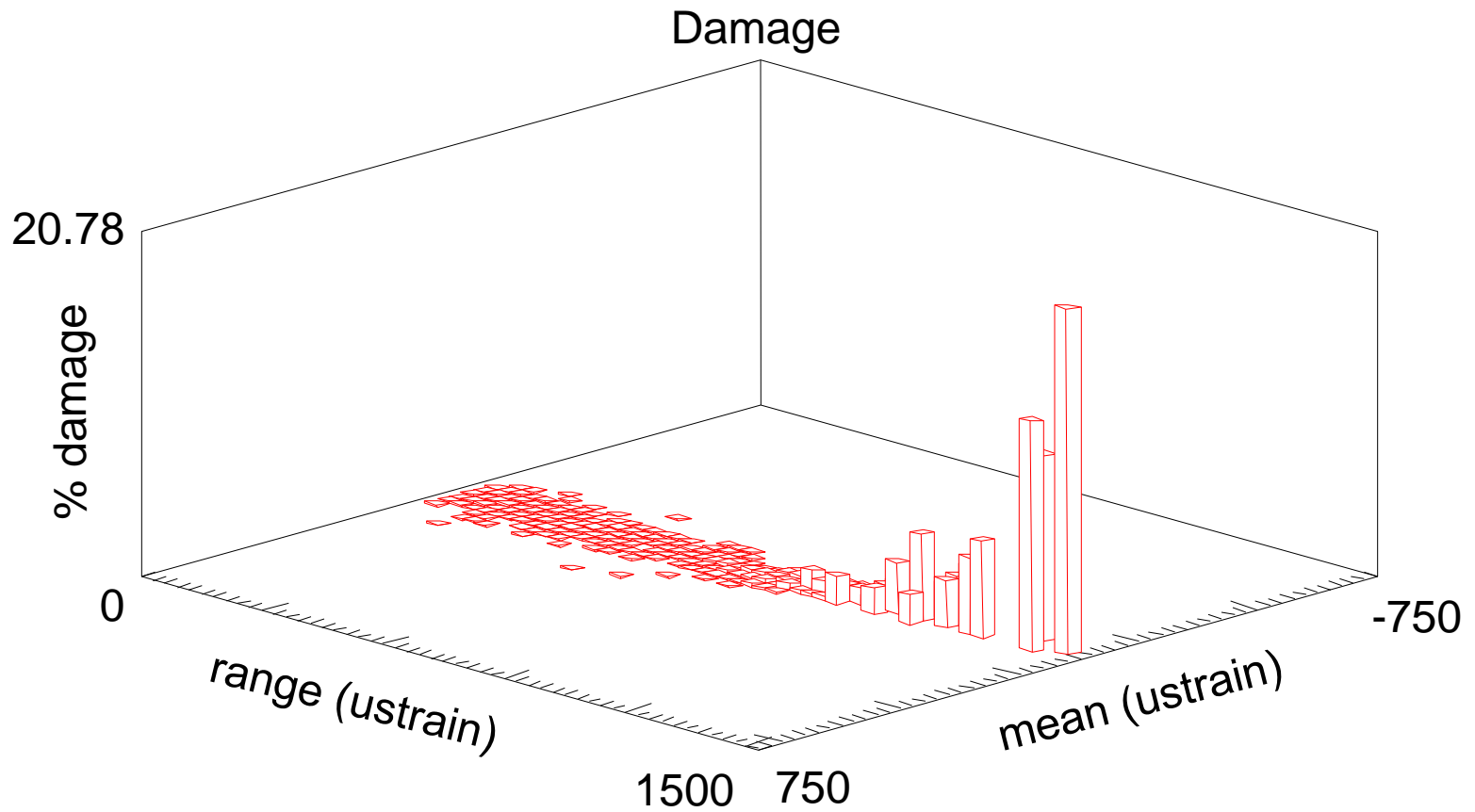

# Mechanisms and Slopes

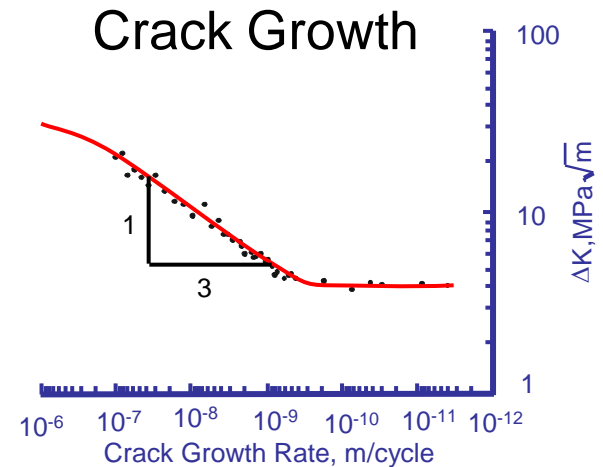
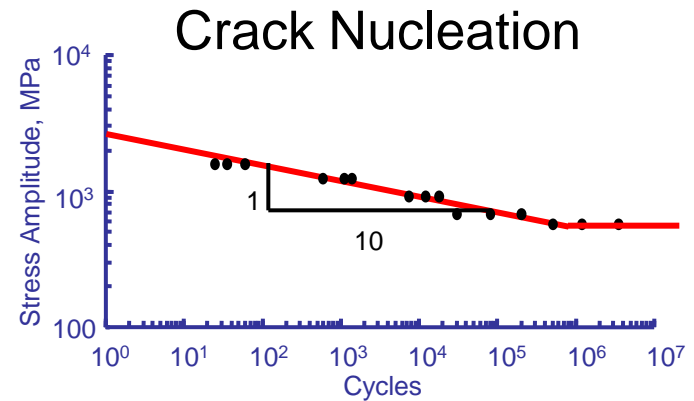
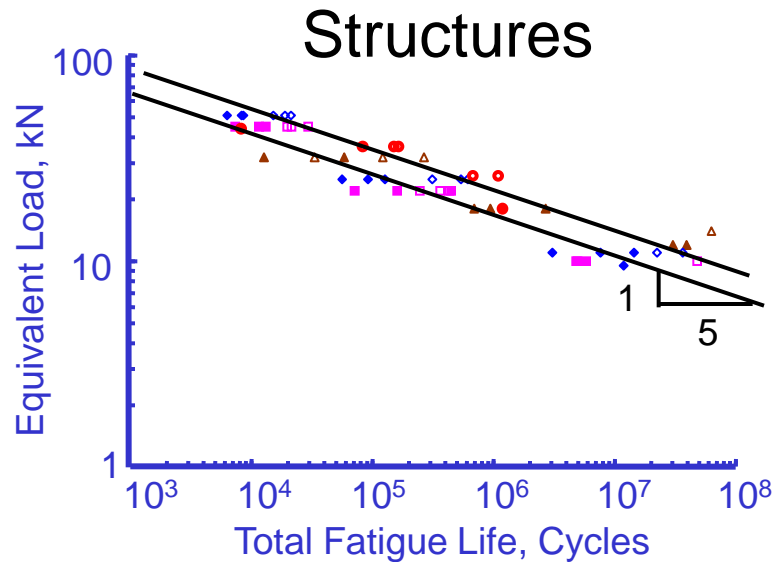

A combination of nucleation and growth



# Equivalent Load

---

Equivalent constant amplitude loading

$$\Delta \bar{S} = \sqrt[n]{\frac{\sum_{i=1}^N \Delta S_i^n}{N}}$$

Typically n ranges from 4 to 6 for structures

N cycles at an amplitude of  $\Delta \bar{S}$  does as much damage as the entire loading history

# SAE Keyhole Specimen

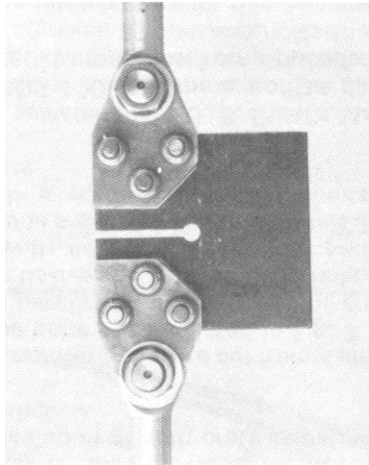

Bracket

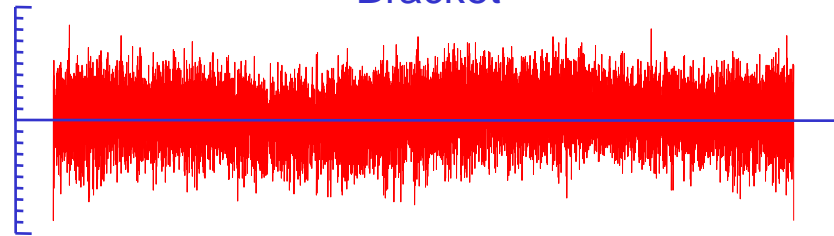

Suspension

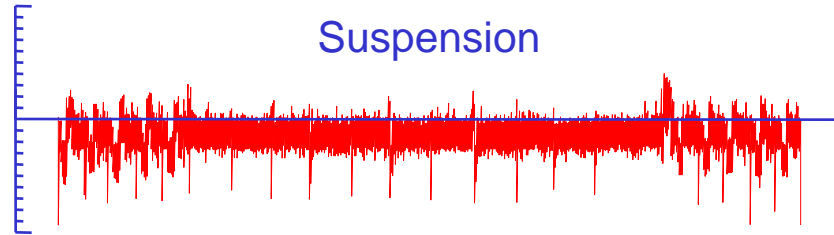

Transmission

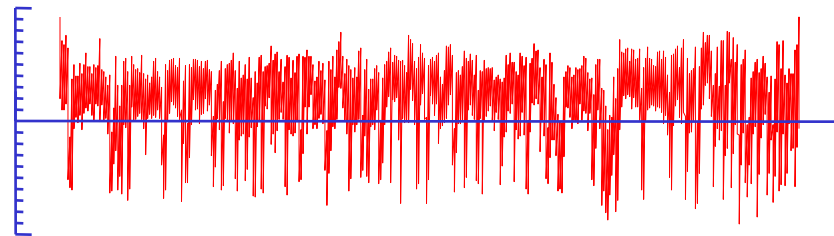

# SAE Keyhole Test Data

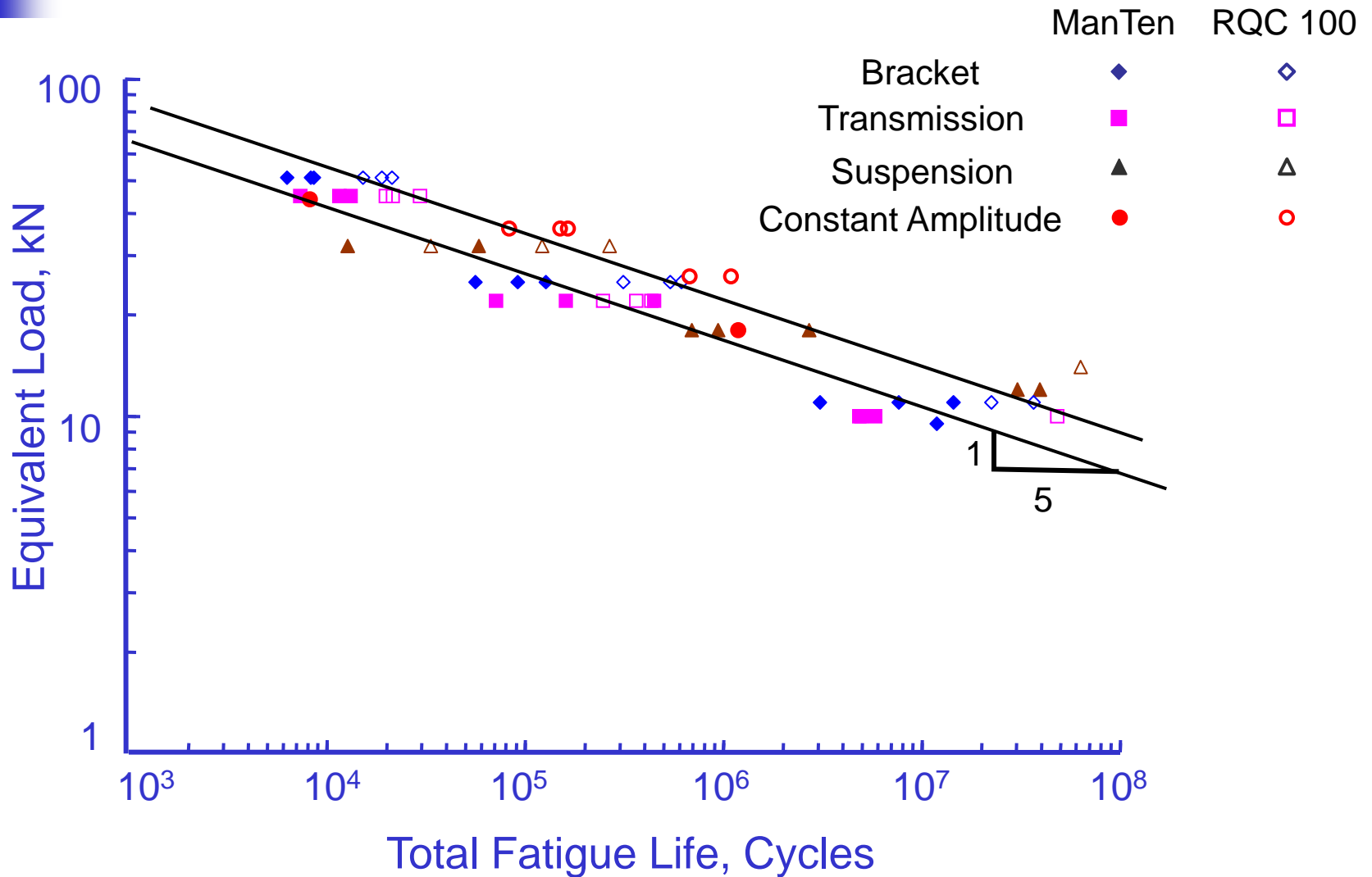



# Things Worth Remembering

---

- Rainflow counting is employed to identify cycles
- The slope of the fatigue curve ( damage mechanism) has a large influence on how much damage is caused by smaller cycles



# Factors Influencing Fatigue

---

- Mean Stress
- Variable Amplitude
- **Stress Concentrations**
- Surface Finish



# Stress Concentration Factor

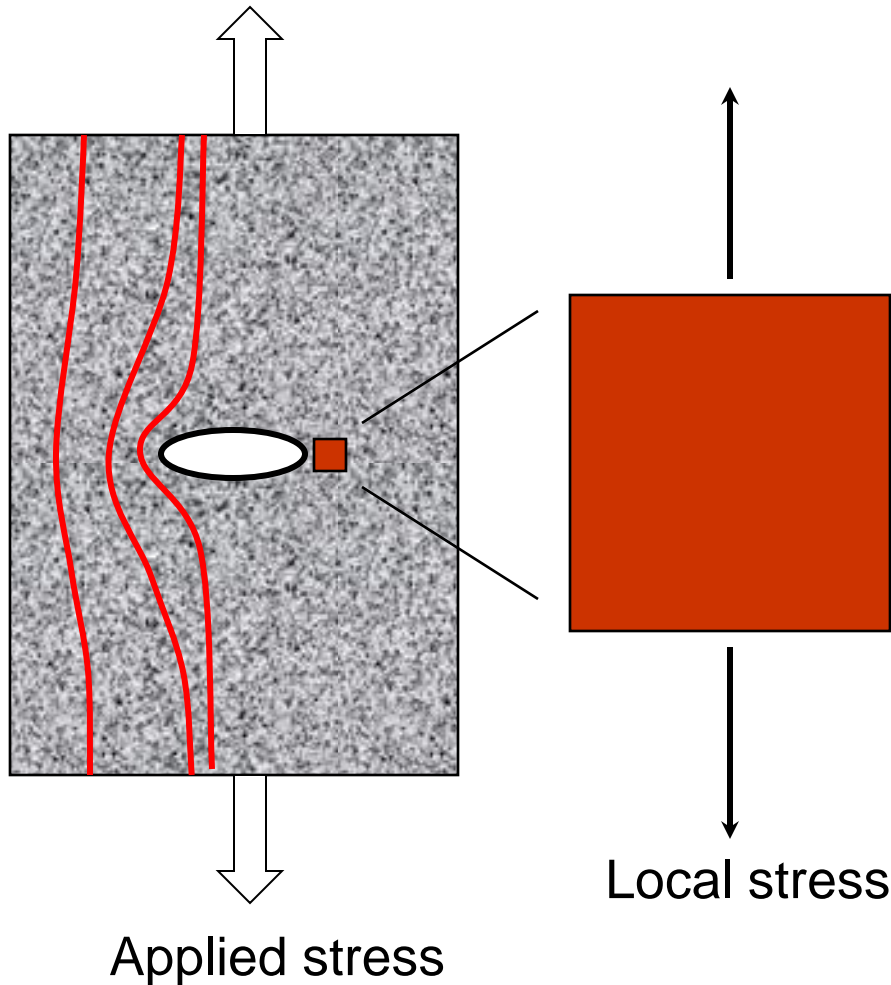

$$\sigma_{\text{local}} = \sigma_{\text{applied}} \left( 1 + 2 \sqrt{\frac{a}{\rho}} \right)$$

Inglis Solution 1910

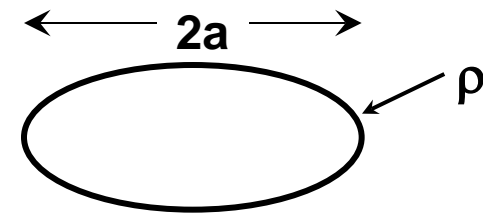

# $K_\sigma$ and $K_\epsilon$

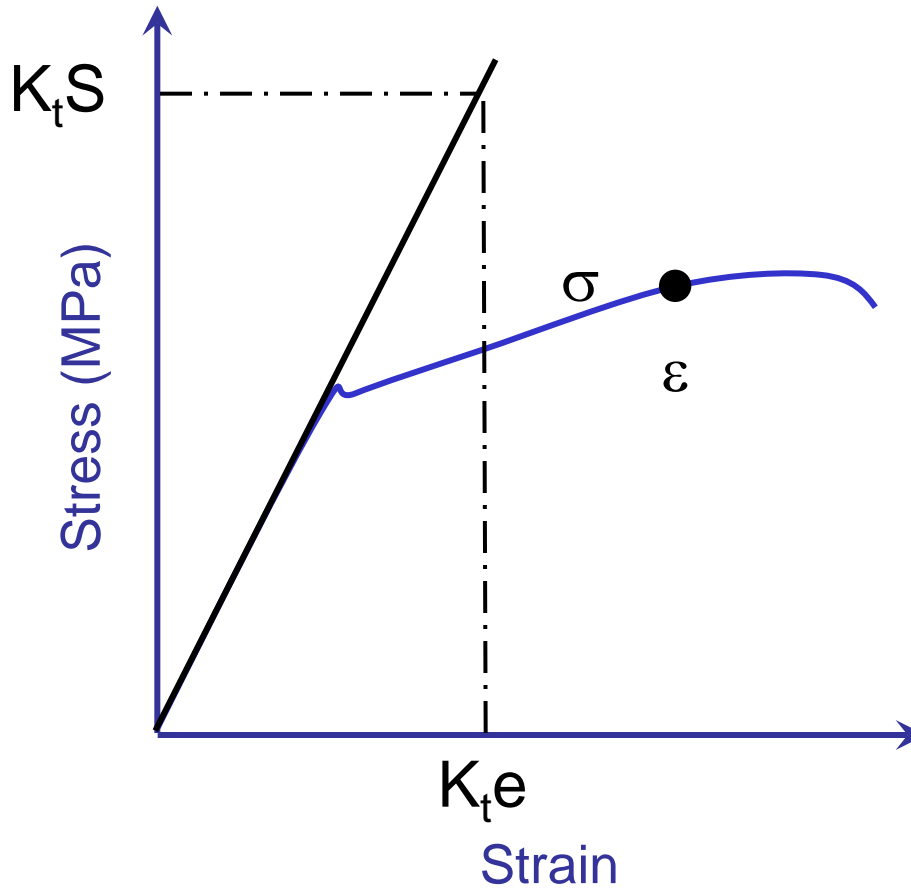

$$K_\sigma = \frac{\sigma}{S}$$

$$K_\epsilon = \frac{\epsilon}{e}$$

# Neuber's Rule

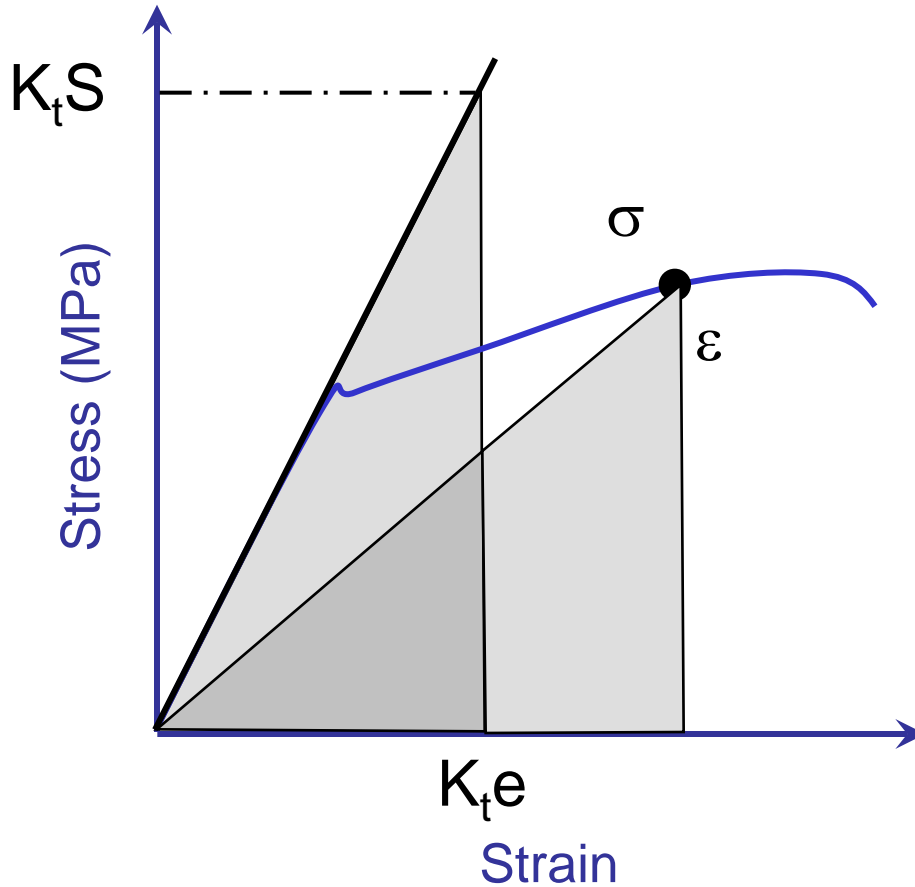

Actual stress

$$\underbrace{K_t S}_{\text{Stress calculated with elastic assumptions}} K_t e = \sigma \epsilon$$

Stress calculated with elastic assumptions



# Neuber's Rule for Fatigue

---

Stress and strain amplitudes

$$\frac{K_t \frac{\Delta S}{2}}{2} = \frac{K_t \frac{\Delta e}{2}}{2} = \frac{\Delta \sigma \Delta \varepsilon}{2 \cdot 2}$$

Elastic nominal stress

$$\frac{\Delta e}{2} = \frac{\Delta S}{2E}$$

Substitute and rearrange

$$K_t \frac{\Delta S}{2} = \sqrt{E \frac{\Delta \sigma}{2} \frac{\Delta \varepsilon}{2}}$$

The product of stress times strain controls fatigue life



# A Dilemma

---

Stress analysis and stress concentration factors are independent of size and are related only to the ratio of the geometric dimensions to the loads

Fatigue is a size dependent phenomenon

How do you put the two together ?

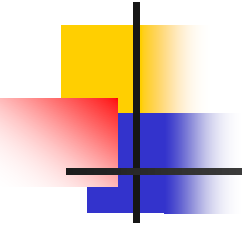

# Similitude

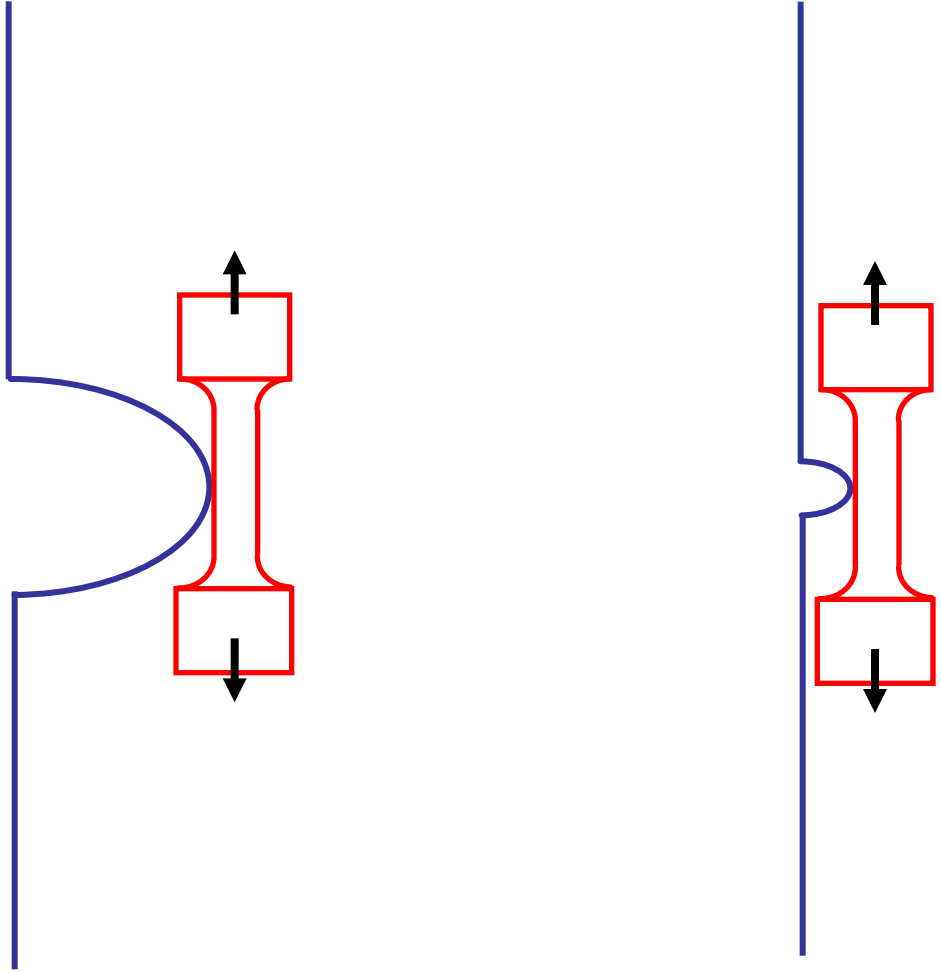

# Fatigue of Notches

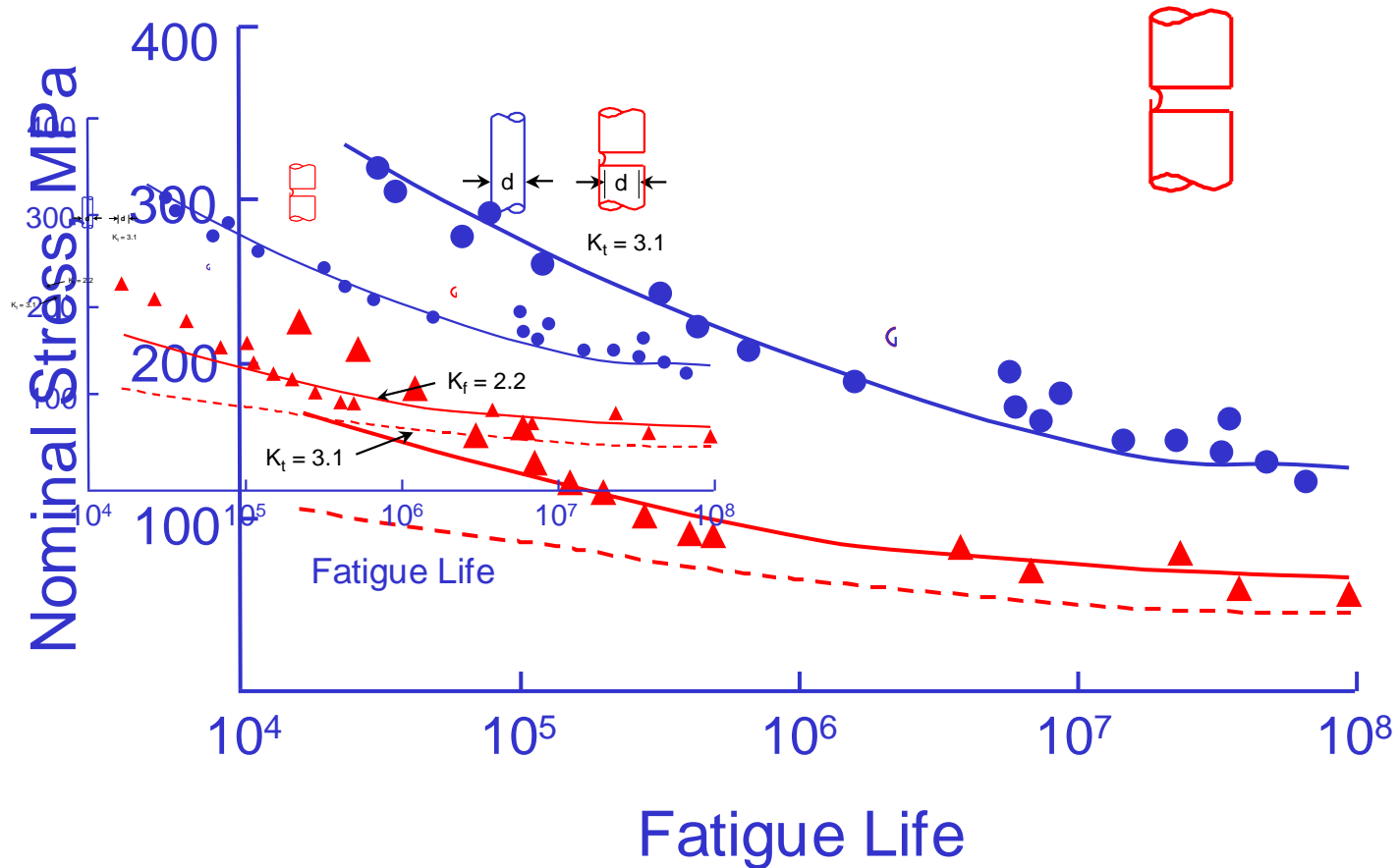

From Dowling, Mechanical Behavior of Materials, 1999

# Notch Size

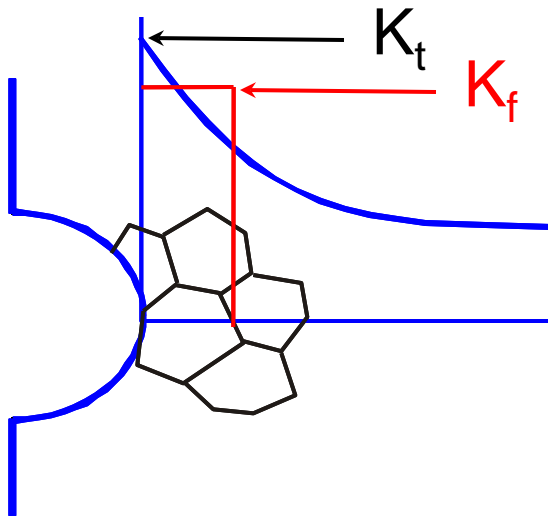

Large Notch

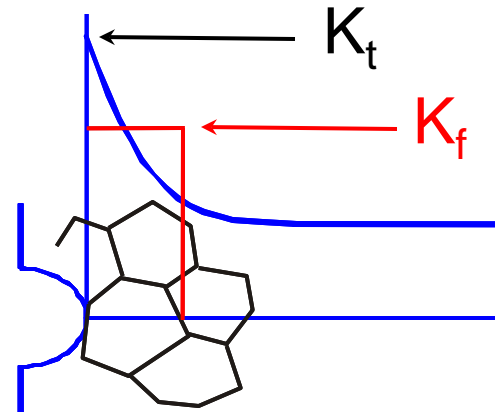

Small Notch



# Microstructure Size

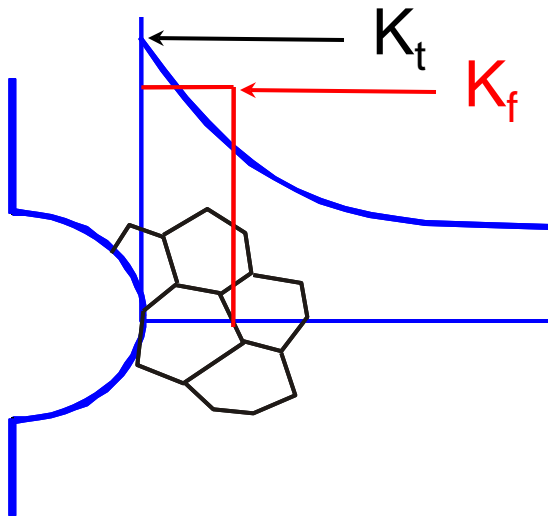

Low Strength

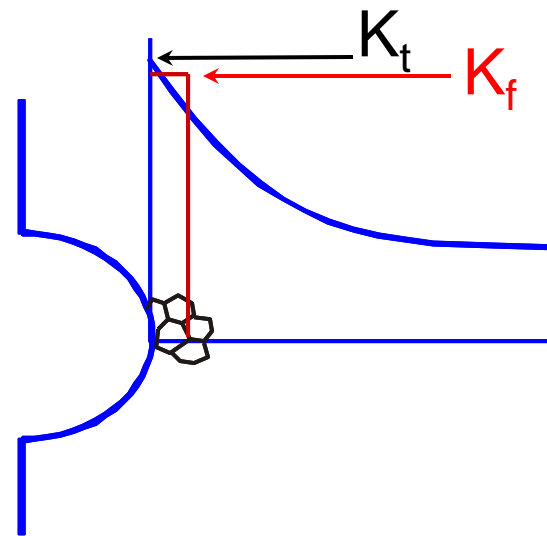

High Strength

# Stress Gradient

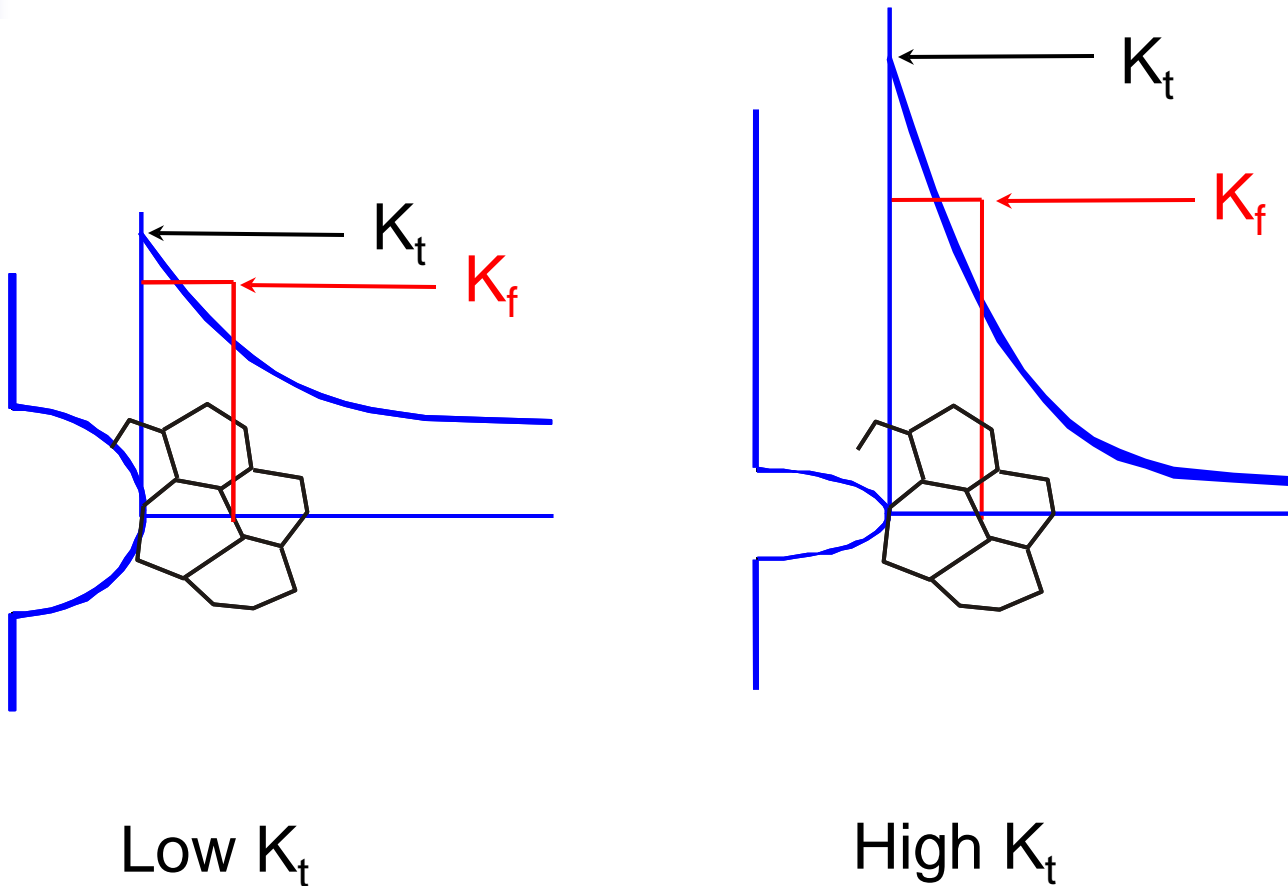

# $K_t$ vs $K_f$

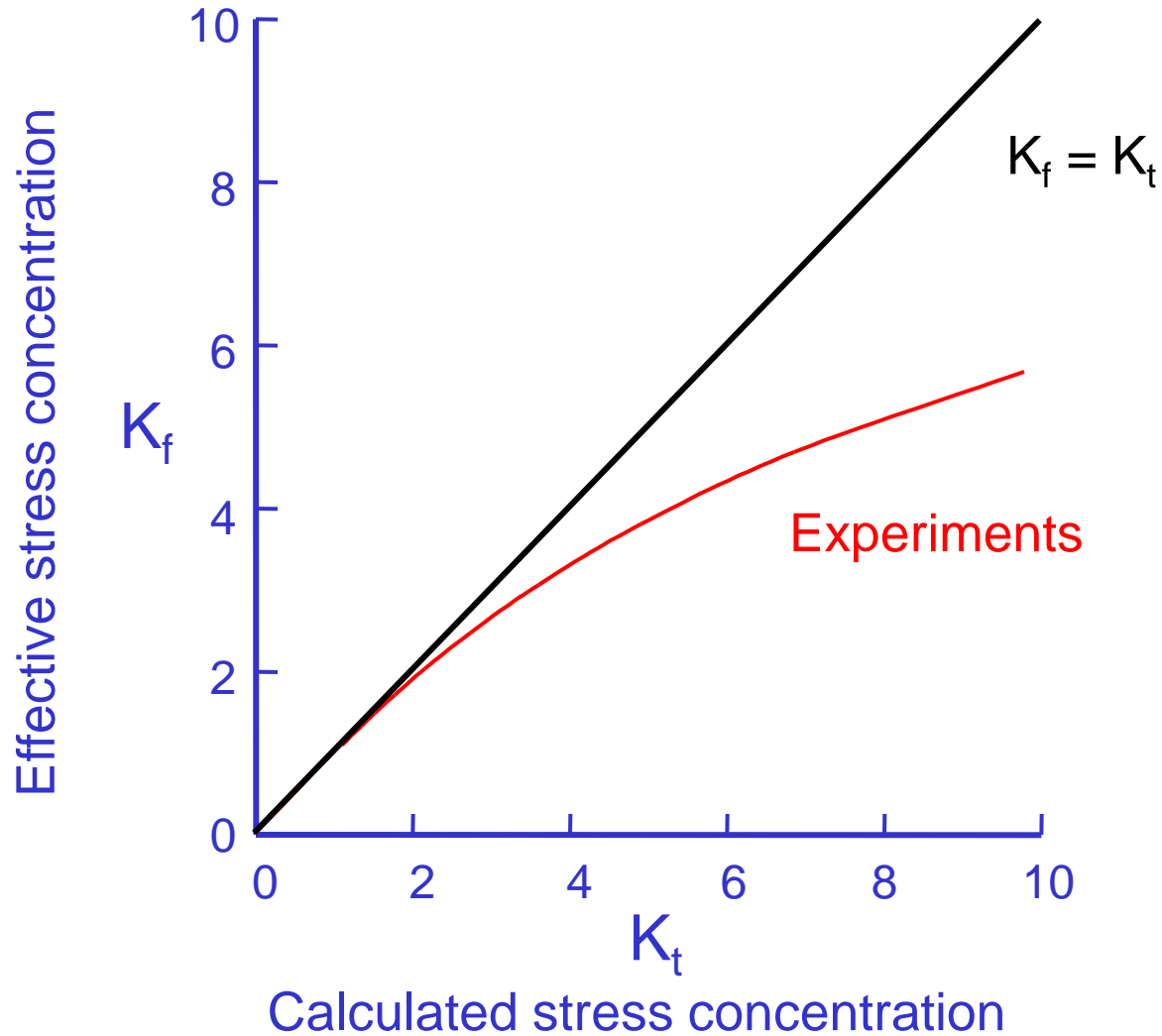

# Peterson's Equation

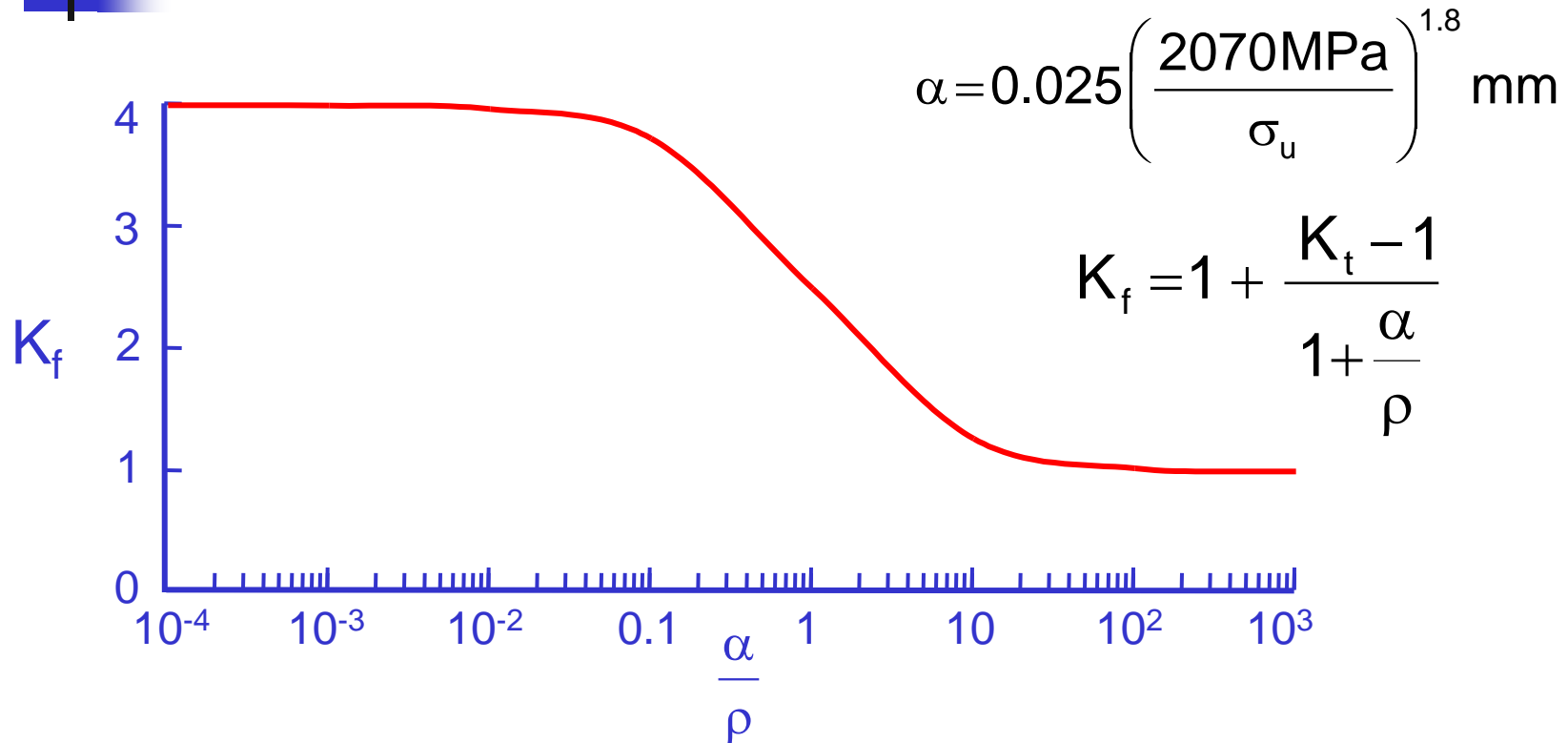

No effect when  $\rho \ll \alpha$

Full effect when  $\rho \gg \alpha$

# Peterson's Constant

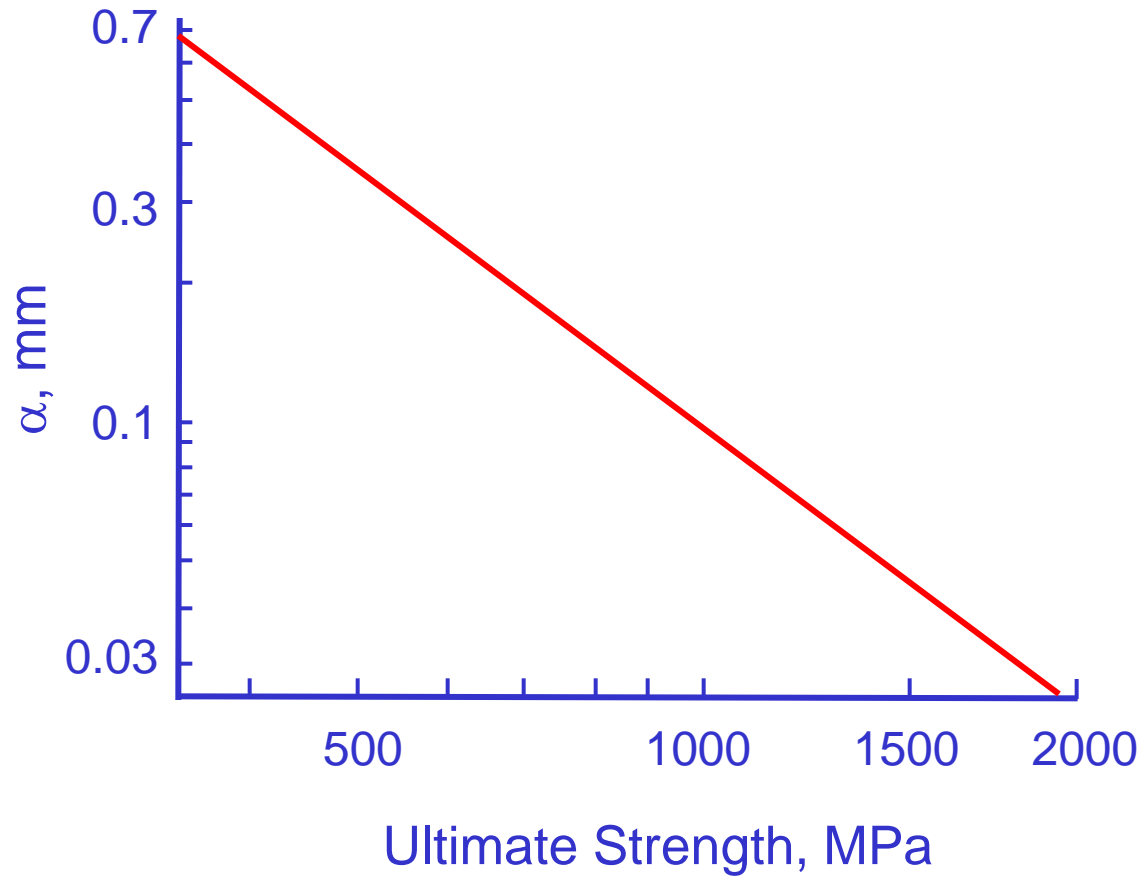



# Static Strength

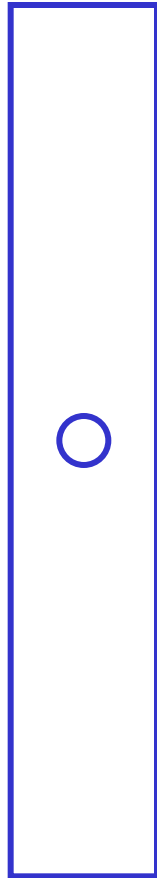

hole  
 $K_t = 2.5$

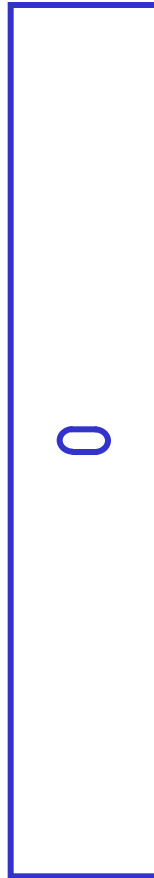

slot  
 $K_t = 5$

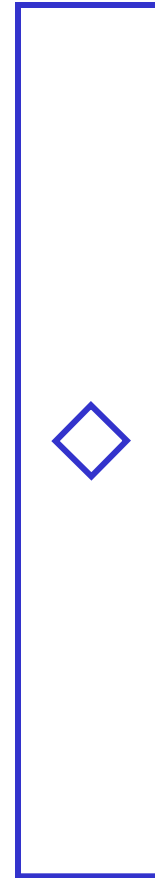

diamond  
 $K_t = 20$

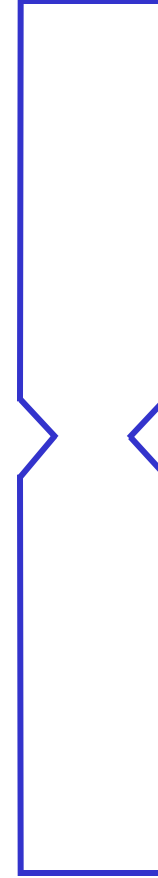

edge  
 $K_t = 20$

# 1018 Steel Test Data

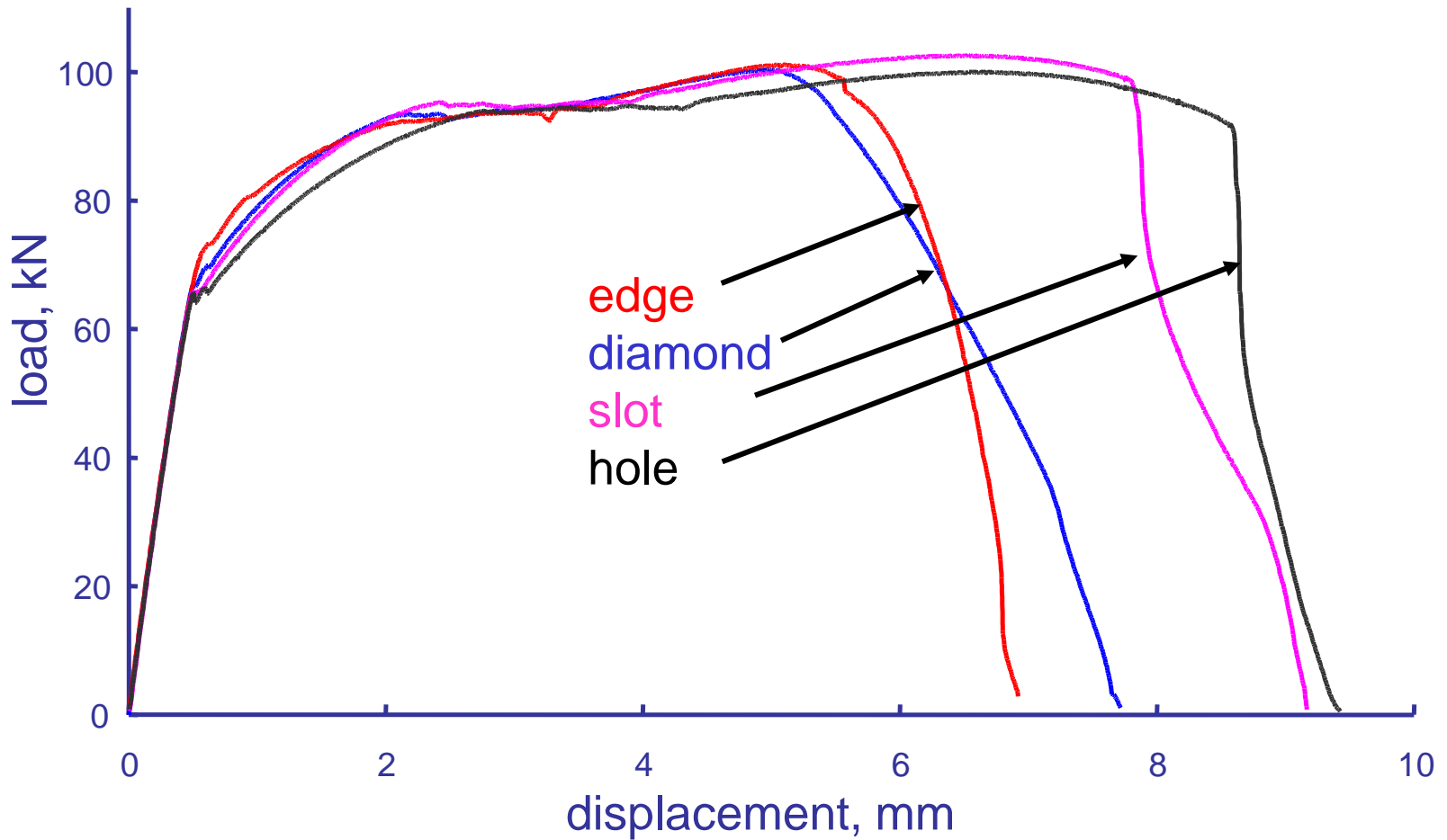

# Notched SN Curve

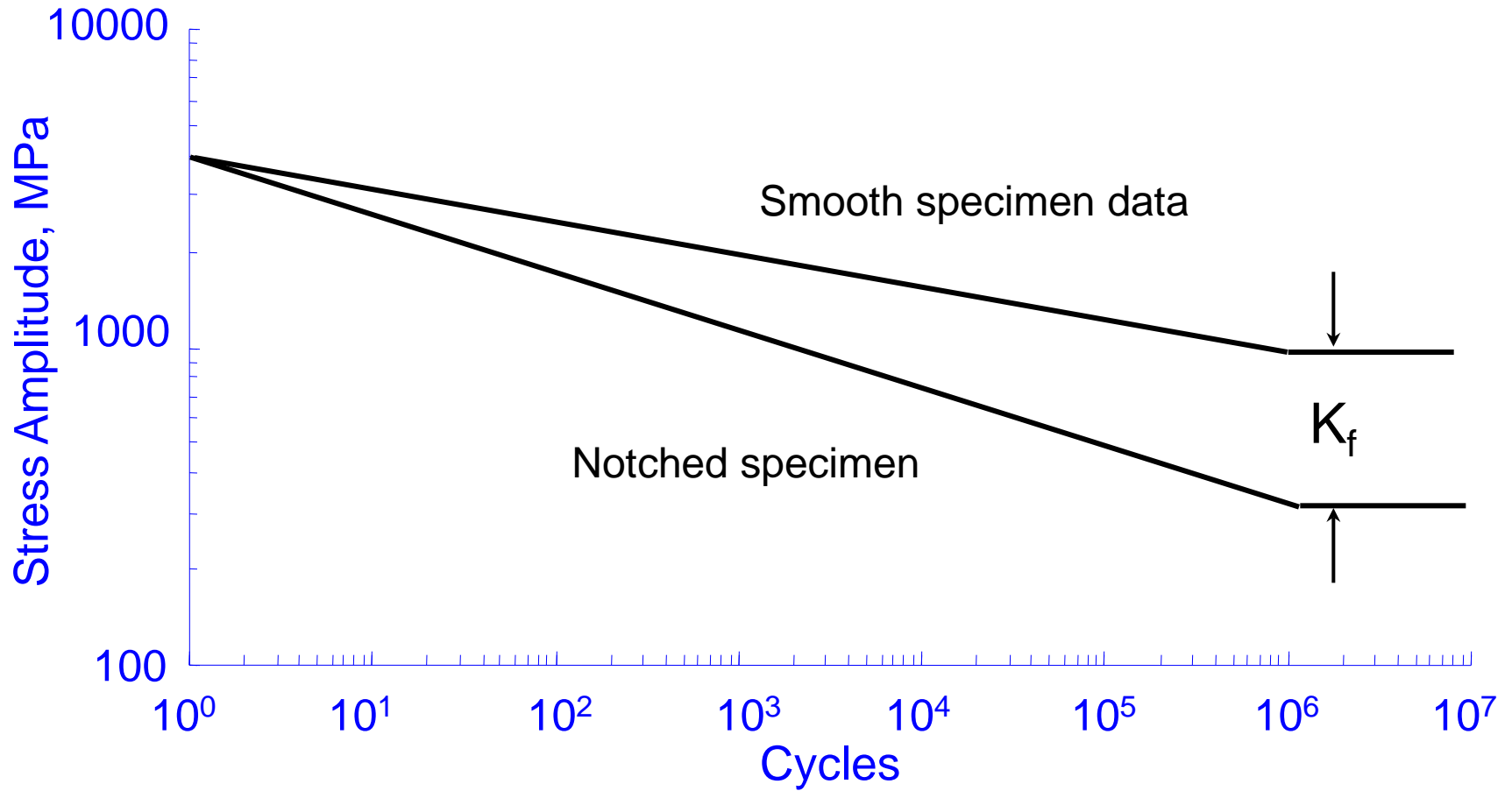

Stress concentrations are not very important at short lives



# Fatigue of Notches

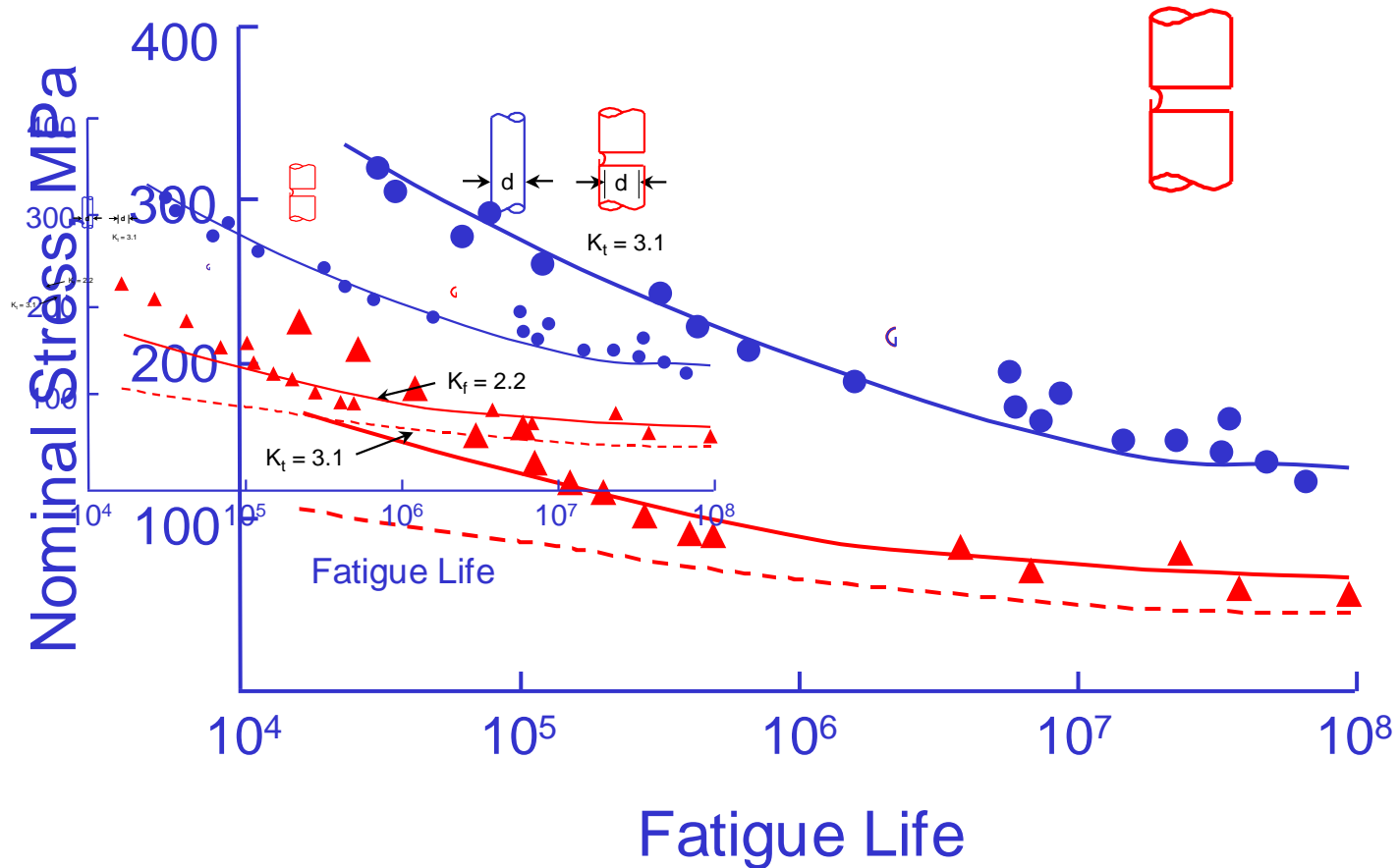

From Dowling, Mechanical Behavior of Materials, 1999

# Crack Growth Data

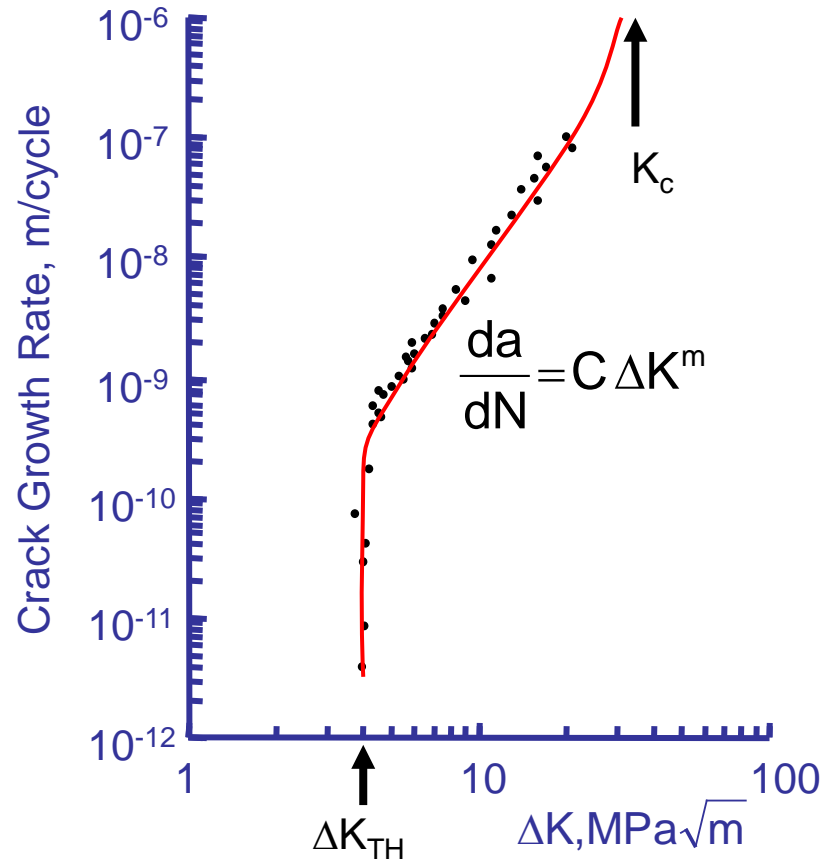

Nonpropagating cracks

$$\Delta K_{TH} > \Delta \sigma 1.12 \frac{2}{\pi} \sqrt{\pi a}$$

# Frost Data

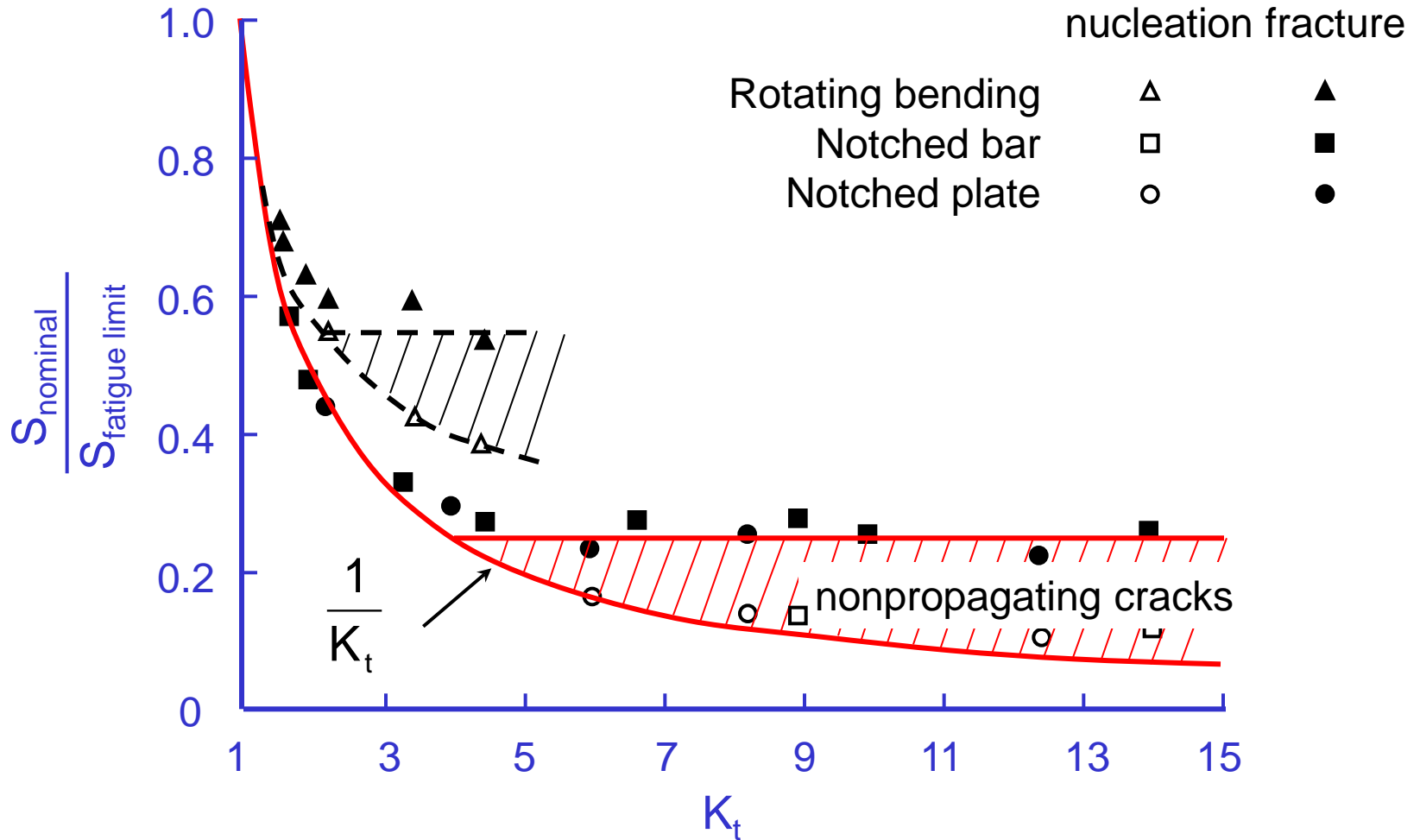

Frost, "A Relation Between the Critical Alternating Propagation Stress and Crack Length for Mild Steel"  
 Proceedings of the Institute for Mechanical Engineers, Vol. 173, No. 35, 1959, 811-836



# Significance

---

For  $K_t > 4$ , the notch acts like a crack with a depth  $D$

$$S_{fl} = \frac{\Delta K_{th}}{\sqrt{\pi D}}$$

$K_t$  does not play a role for sharp notches !

A stress concentration behaves like a crack once a stress concentration becomes large ( $K_t > 4$ )

# Cracks at Notches

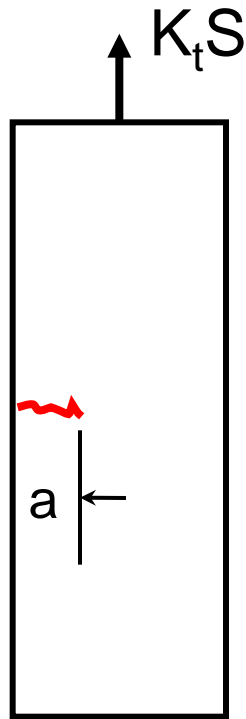
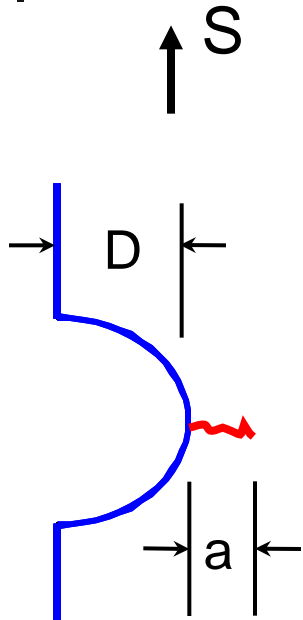

$a \ll D$

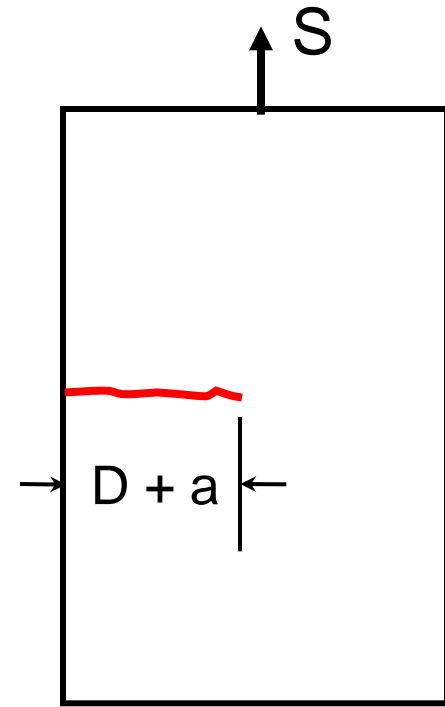

$a \gg D$

# Stress Intensity Factors

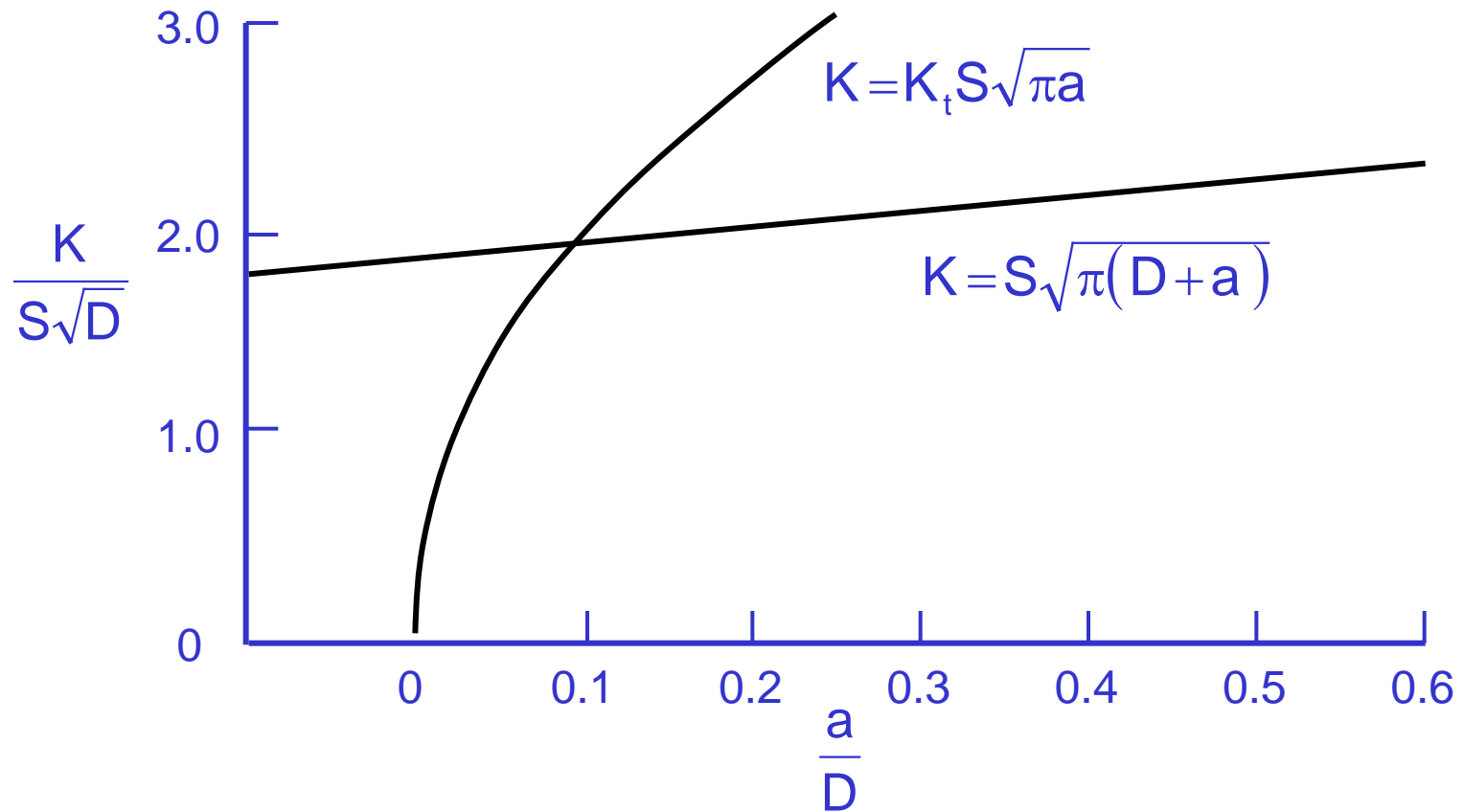

# Cracks at Holes

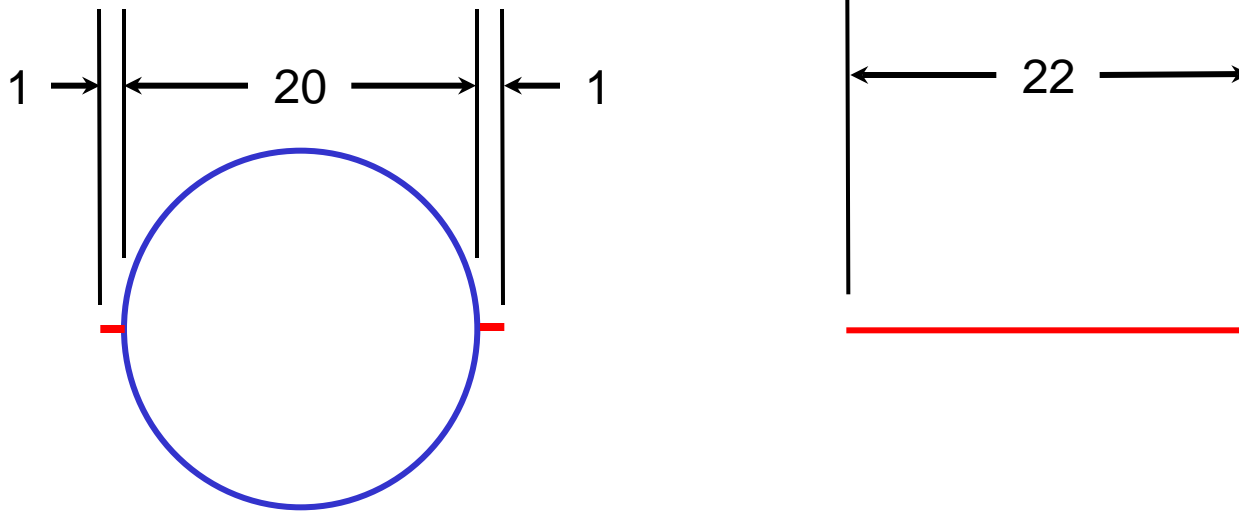

Once a crack reaches 10% of the hole radius, it behaves as if the hole was part of the crack

# Specimens with Similar Geometry

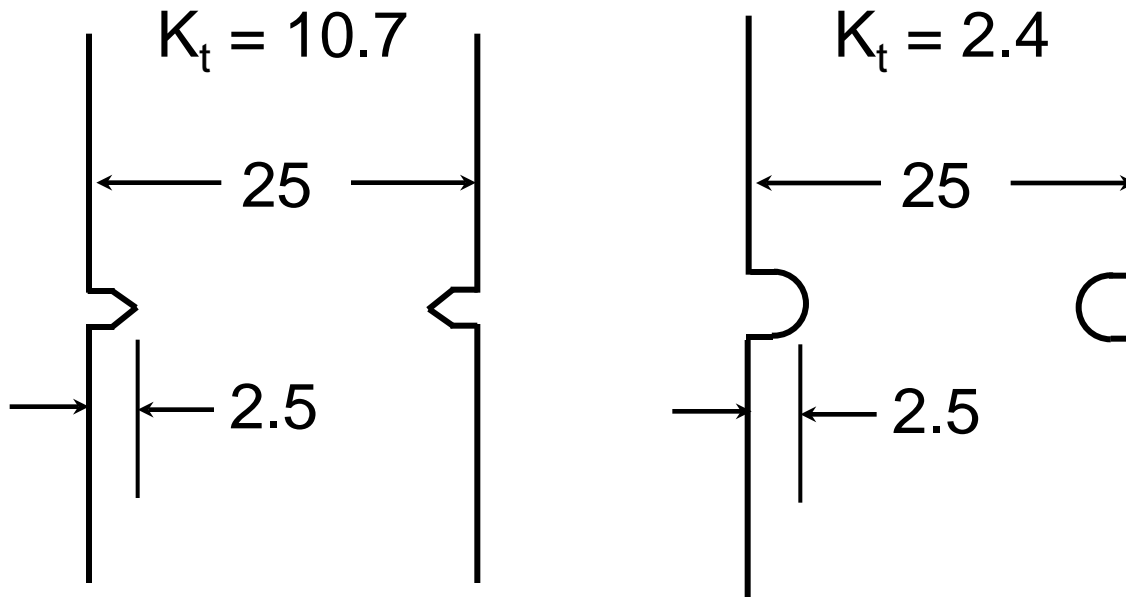

Ultimate Strength 780 MPa  
Yield Strength 660 MPa



# Test Results

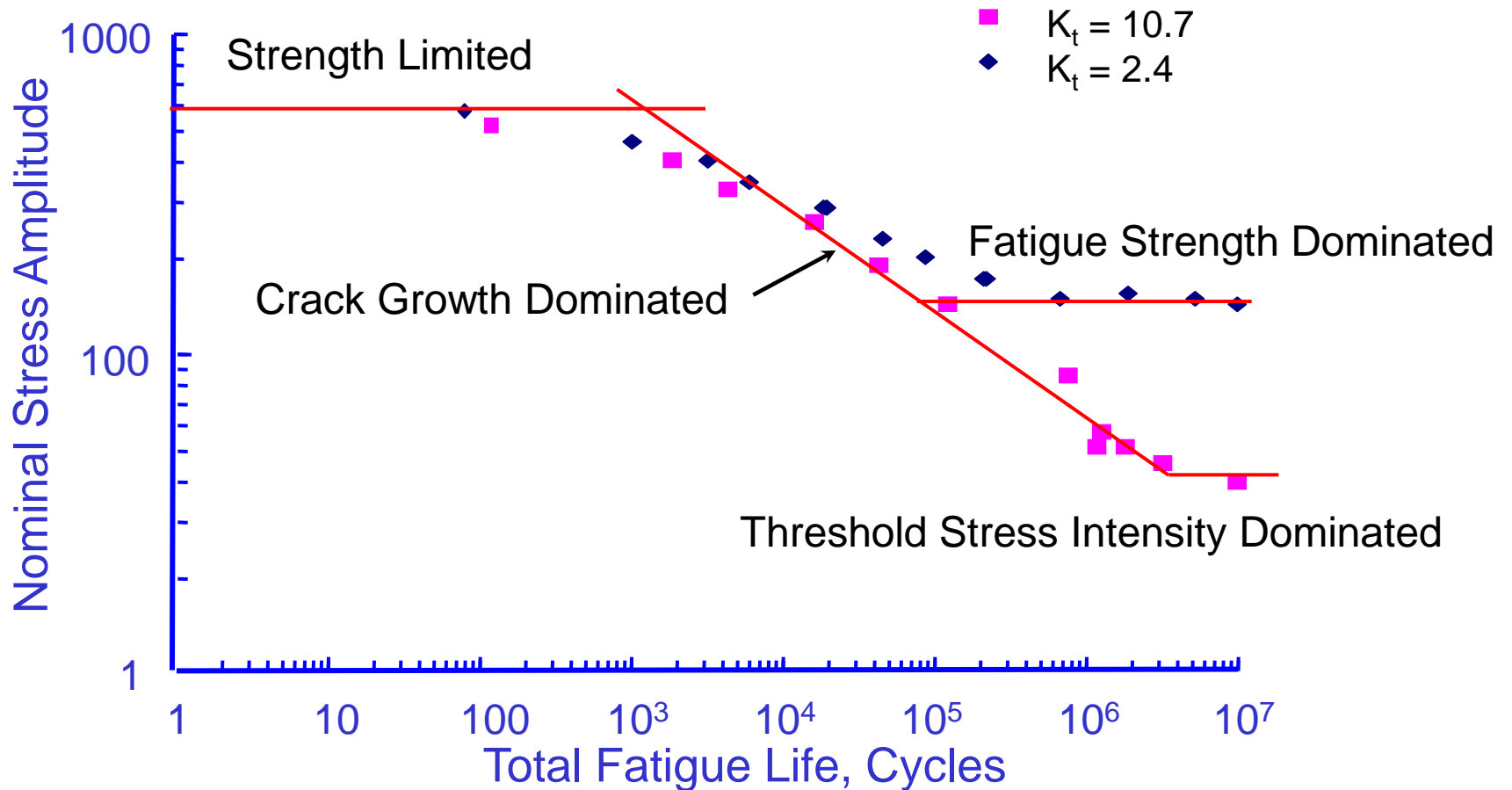



# Things Worth Remembering

---

- Fatigue may be thought of as a failure of the average stress concept, consequently, fatigue usually begins at stress concentrators which are most frequently located on the surface
- The severity of a stress concentrator in fatigue is size dependent
- Small stress concentrators are more effective in high strength materials



# Factors Influencing Fatigue

---

- Mean Stress
- Variable Amplitude
- Stress Concentrations
- **Surface Finish**

# Modern View of the Fatigue Limit

The fatigue limit is the stress where a crack may nucleate but will not grow through the first microstructural barrier such as the grain size, pearlite colony size, prior austenite grain size, eutectic cell size or precipitate spacing.

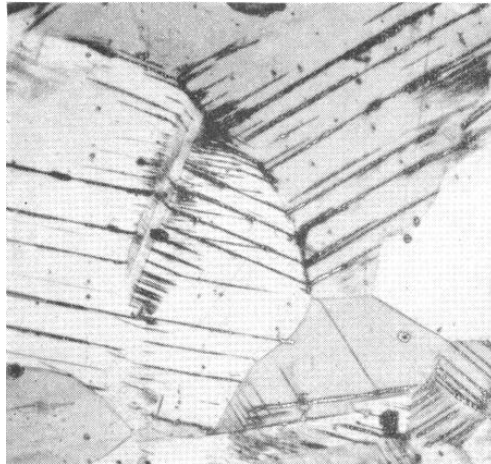

Slip Bands

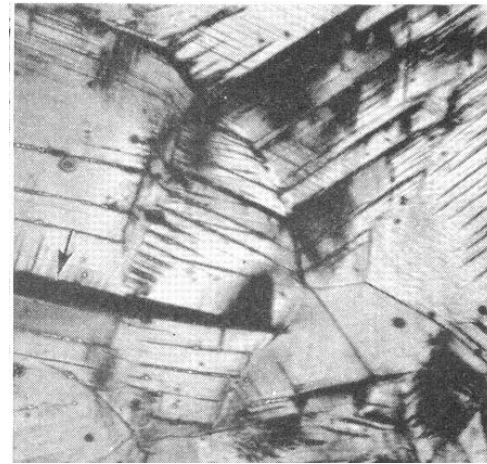

Crack



# Intrinsic Flaws

---

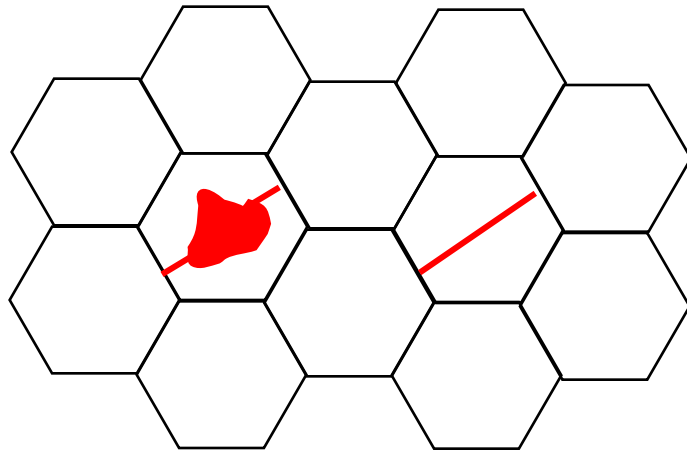

Little effect of surface pit because  
it is smaller than the grain size

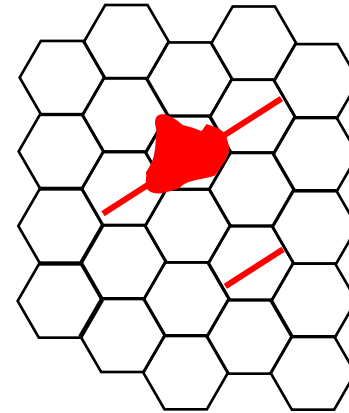

Large effect of defect because  
it is larger than the grain size



# Surface Finish Influence

---

<u>Method</u>	<u>Physics</u>	<u>Size</u>	<u>Influence of Surface Finish</u>
Stress-Life	Crack Nucleation	0.01 mm	Strong
Strain-Life	Microcrack Growth	0.1 - 1 mm	Moderate
Crack Growth	Macrocrack Growth	> 1mm	None



# Sources of Surface Effects

---

- Machining
  - Cutting
  - Grinding
- Corrosion
  - General
  - Pitting
- Processing
  - Cutting/Shearing
  - Casting
  - Forging
  - Plating
- Foreign Object Damage
  - Nicks
  - Scratches

# Machining

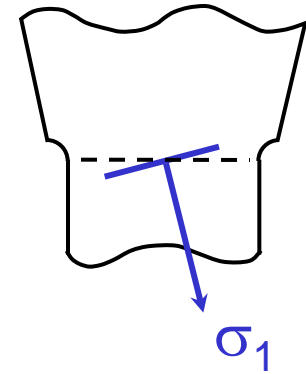
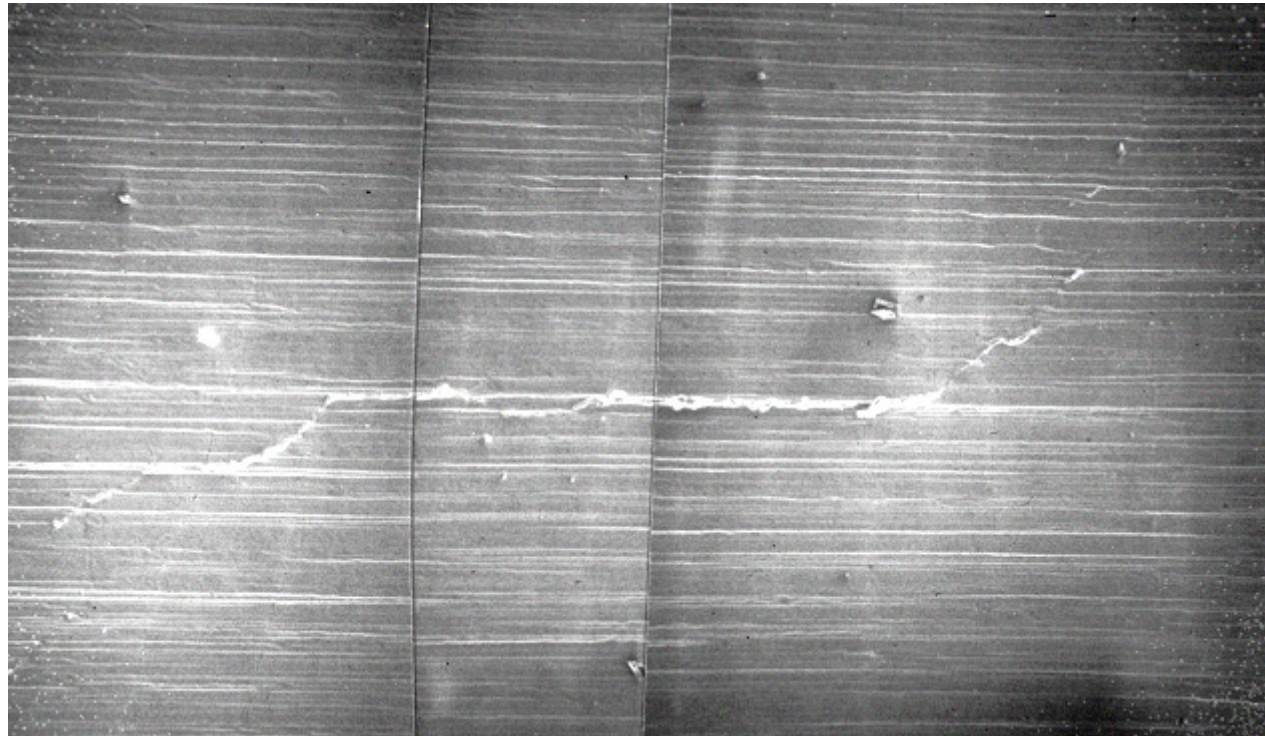

Cracks start in machining marks not in the direction of the maximum principal stress



# Casting



100  $\mu\text{m}$

Surface flaw in gray cast iron

# Nodular Iron Surface

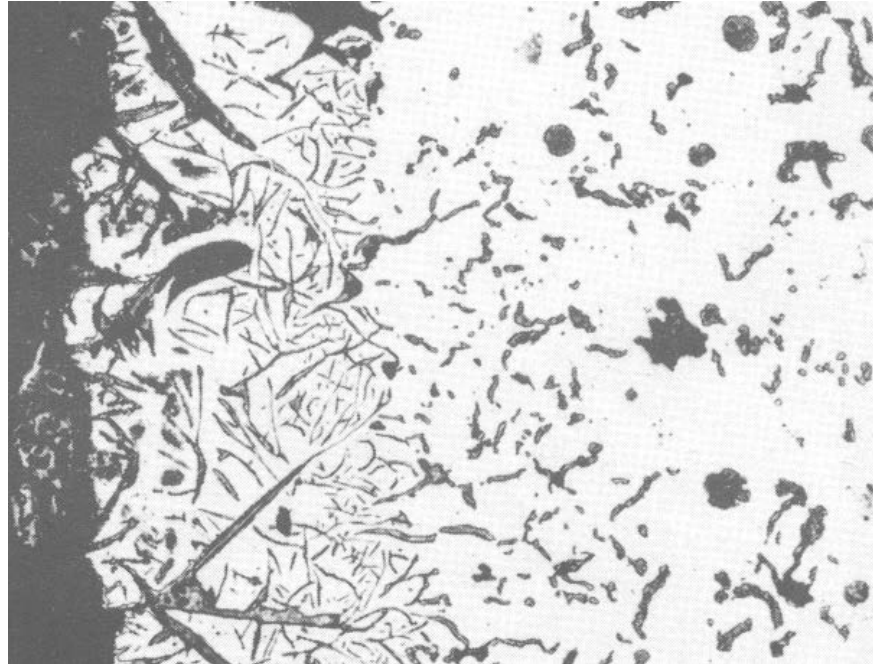

Flake graphite formed on the surface of a nodular iron casting

Starkey and Irving, "A Comparison of the Fatigue Strength of Machined and As-cast Surfaces of SG Iron"  
International Journal of Fatigue, July, 1982, 129-136

# Test Data

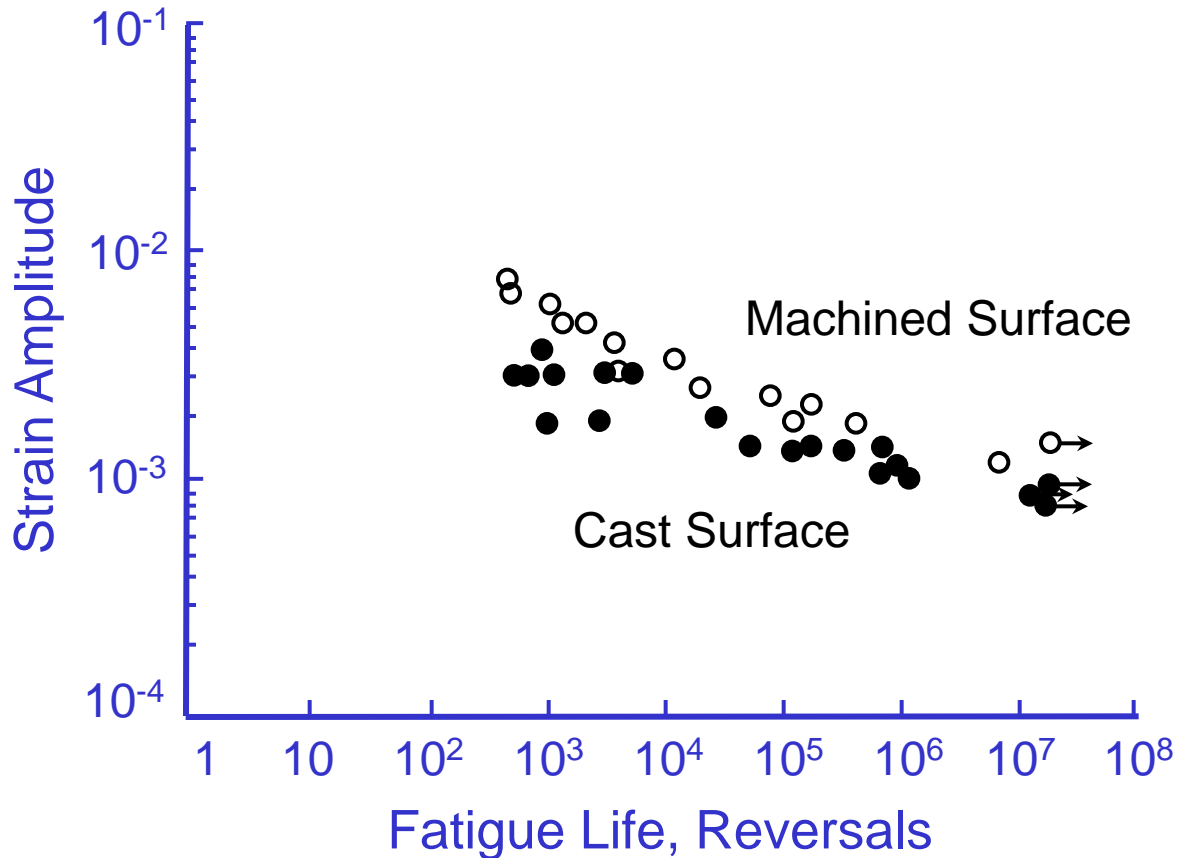

# Surface Reduction Factors

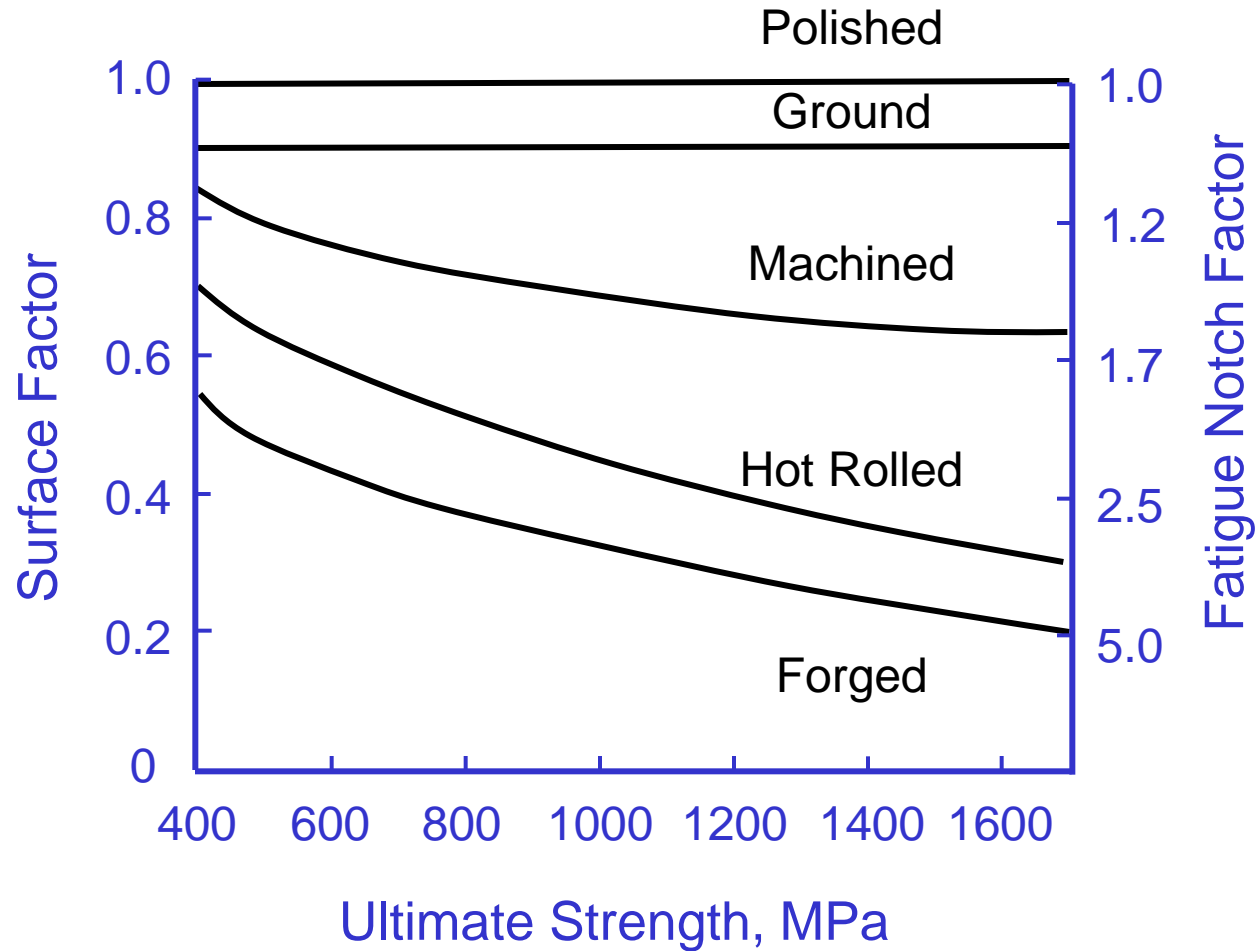

# Noll and Lipson 1945

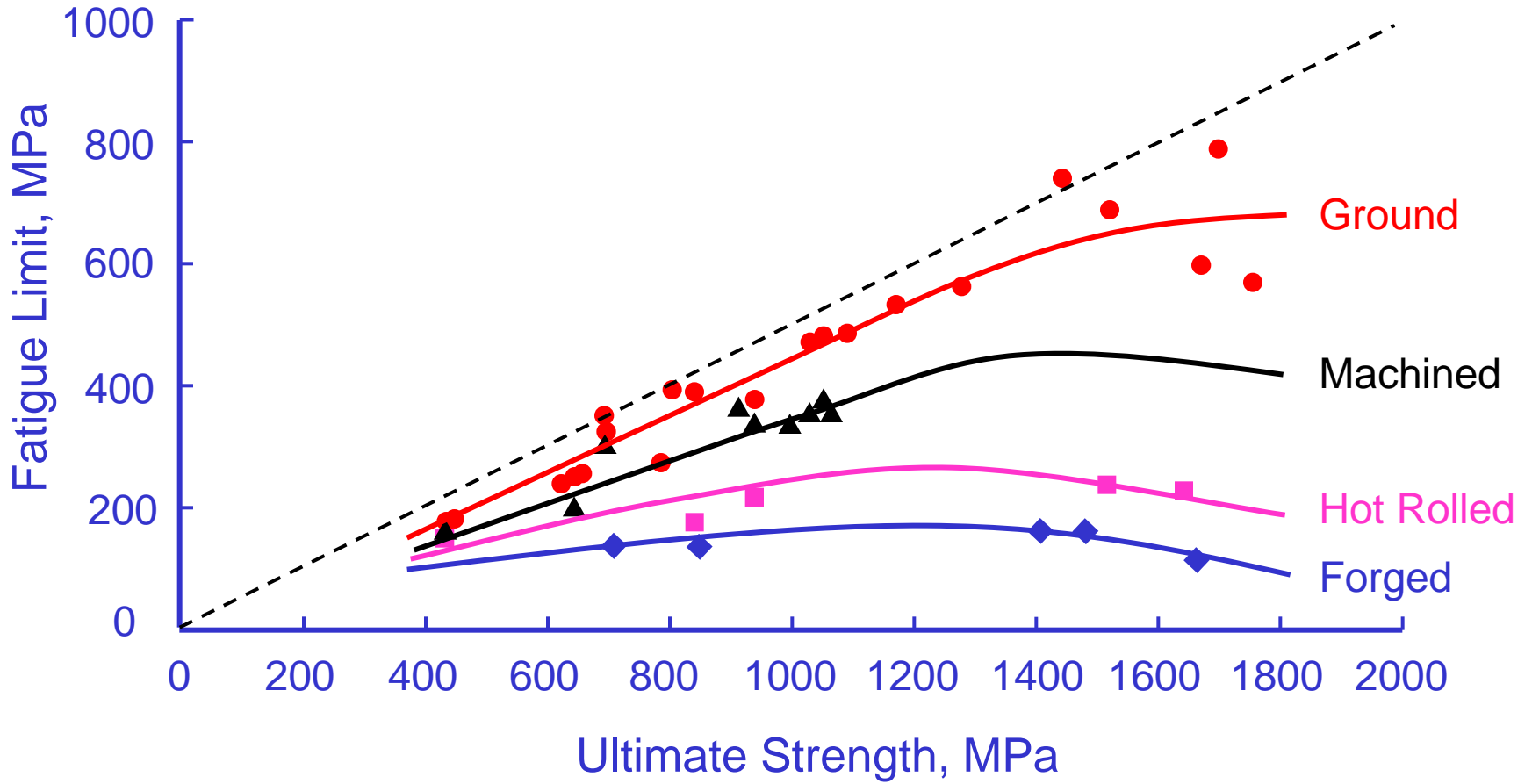

# Hiam and Pietrowski 1978

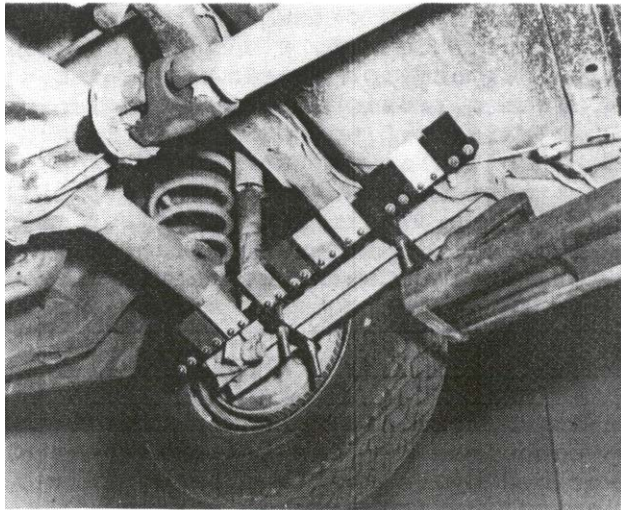

Driven for 1 or 2 years  
in Southern Ontario  
before making specimens  
to evaluate corrosion effects

Strain controlled fatigue testing

Hiam and Pietrowski, "The Influence of Forming and Corrosion on the Fatigue Behavior of Automotive Steels", SAE Paper 780040, 1978



# $K_f$ for pitting

---

	Hot Rolled Surface	Corroded Surface
950X	1.12	1.49
0.06% C HSLA	1.18	1.65
0.18% C HSLA		1.90

Surface finish factor predicts  $K_f = 1.6$  for a Hot Rolled Surface

from Hiam and Pietrowski

# Pit Depth Effects on Life

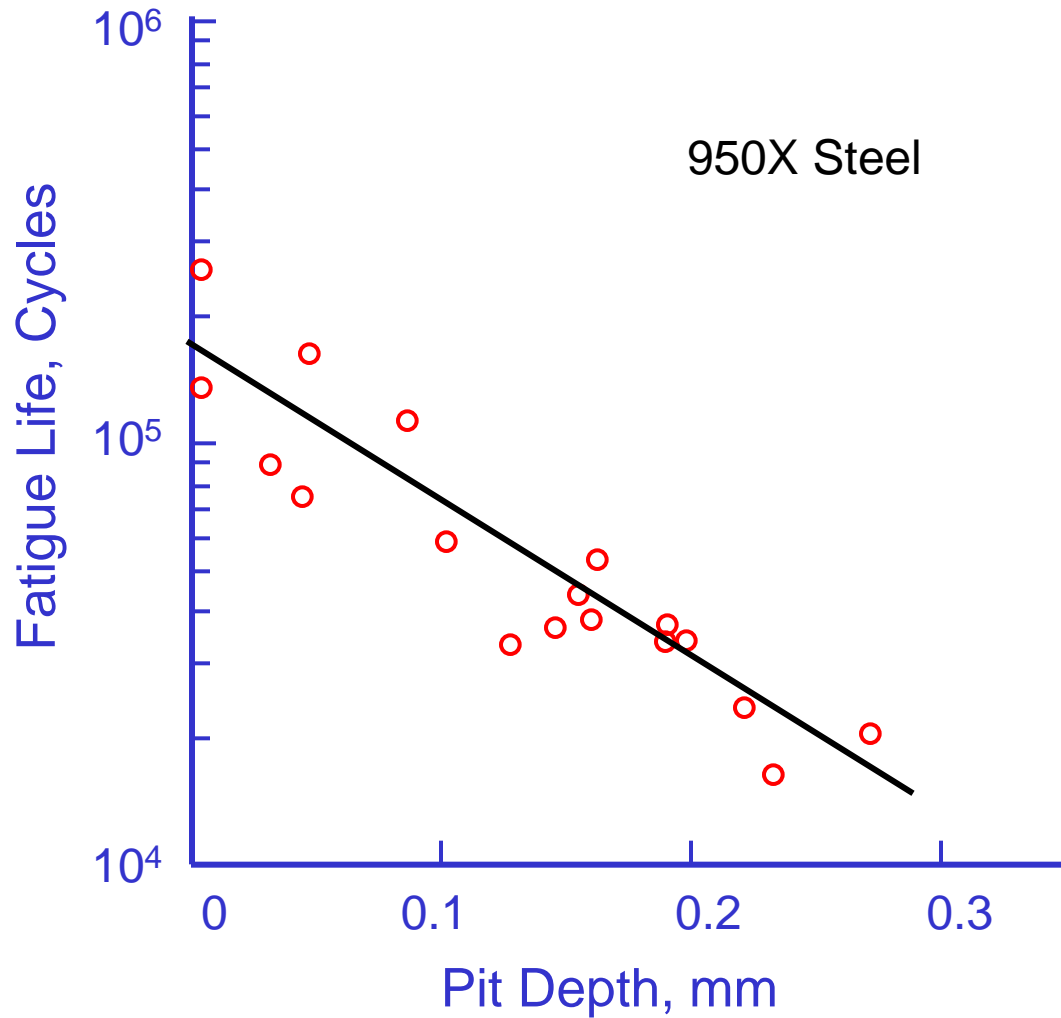

from Hiam and Pietrowski



# Fatigue Notch Factor for Pits

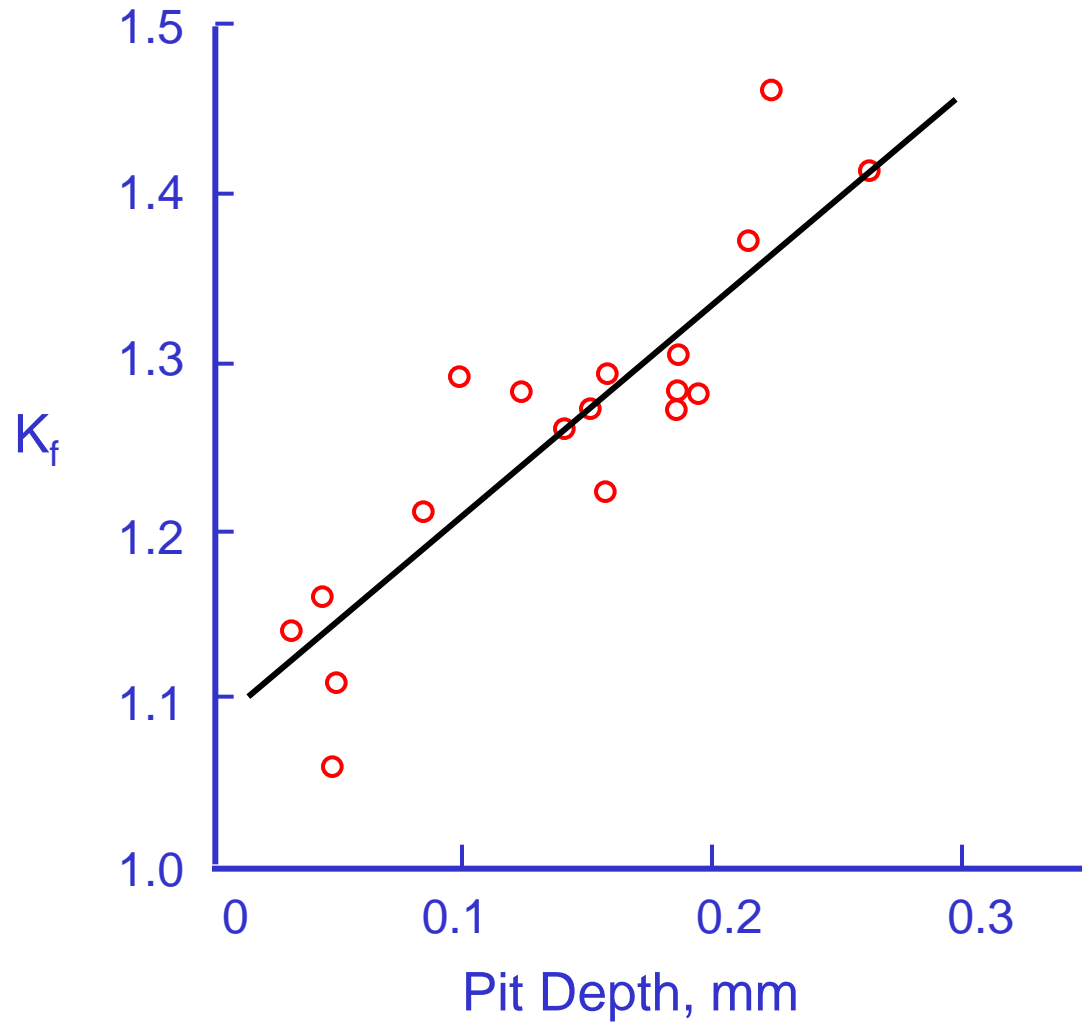

# Suspension

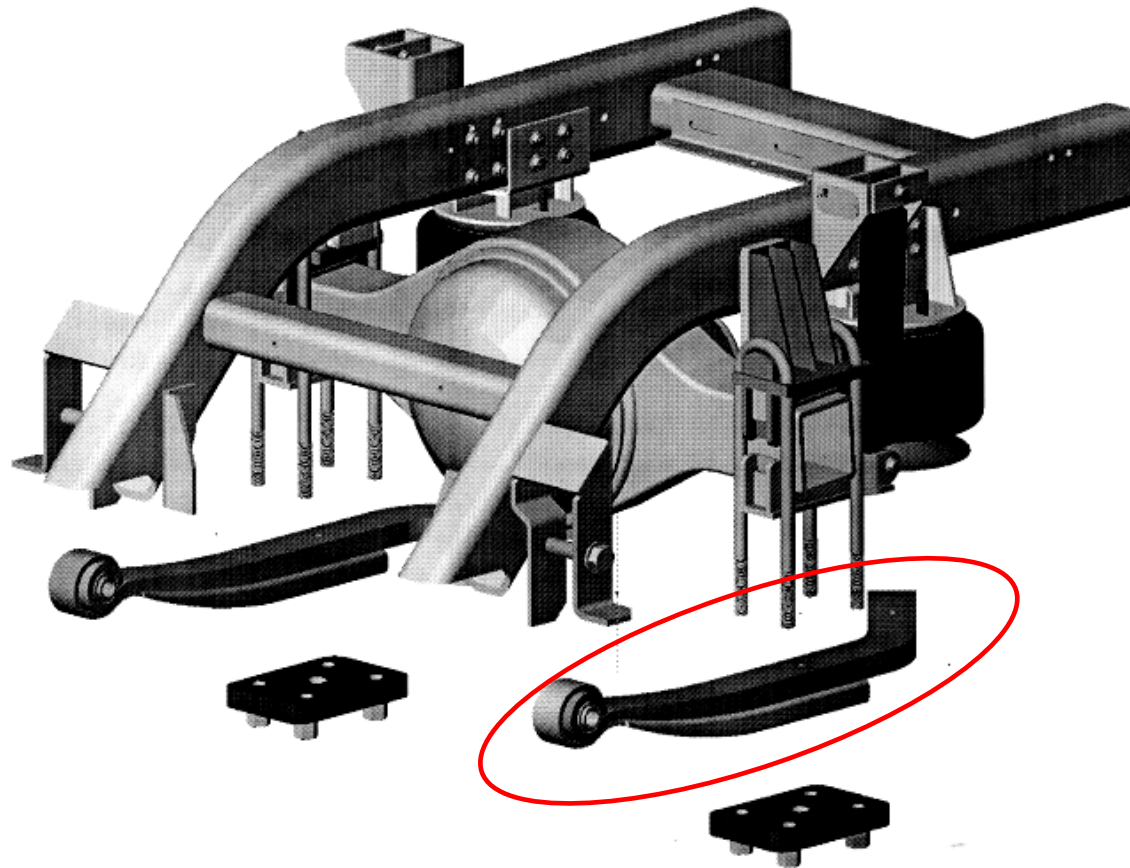

# Spring Failures



# Microscopic Examination

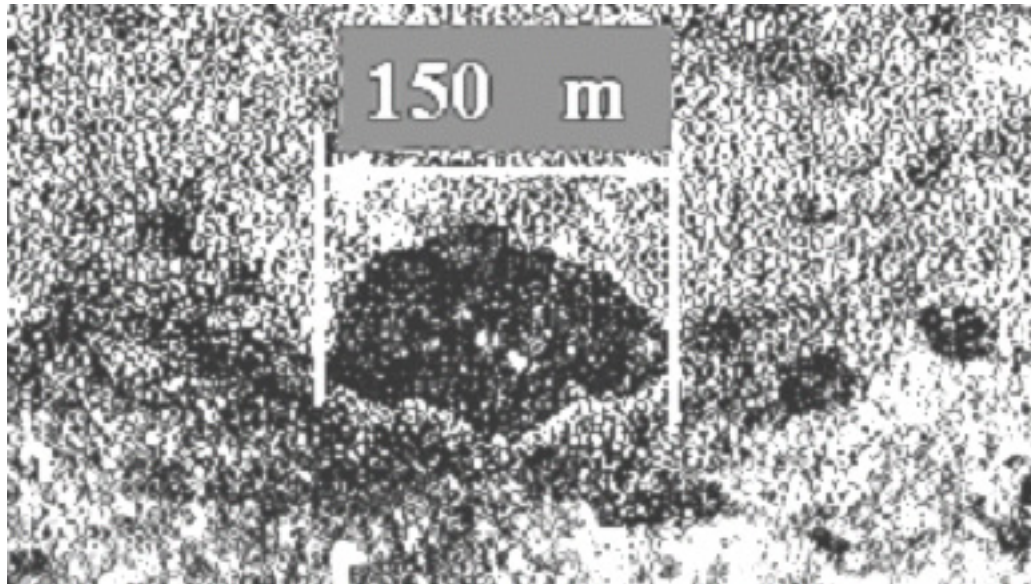

Corrosion Pits

# Chrome Plating

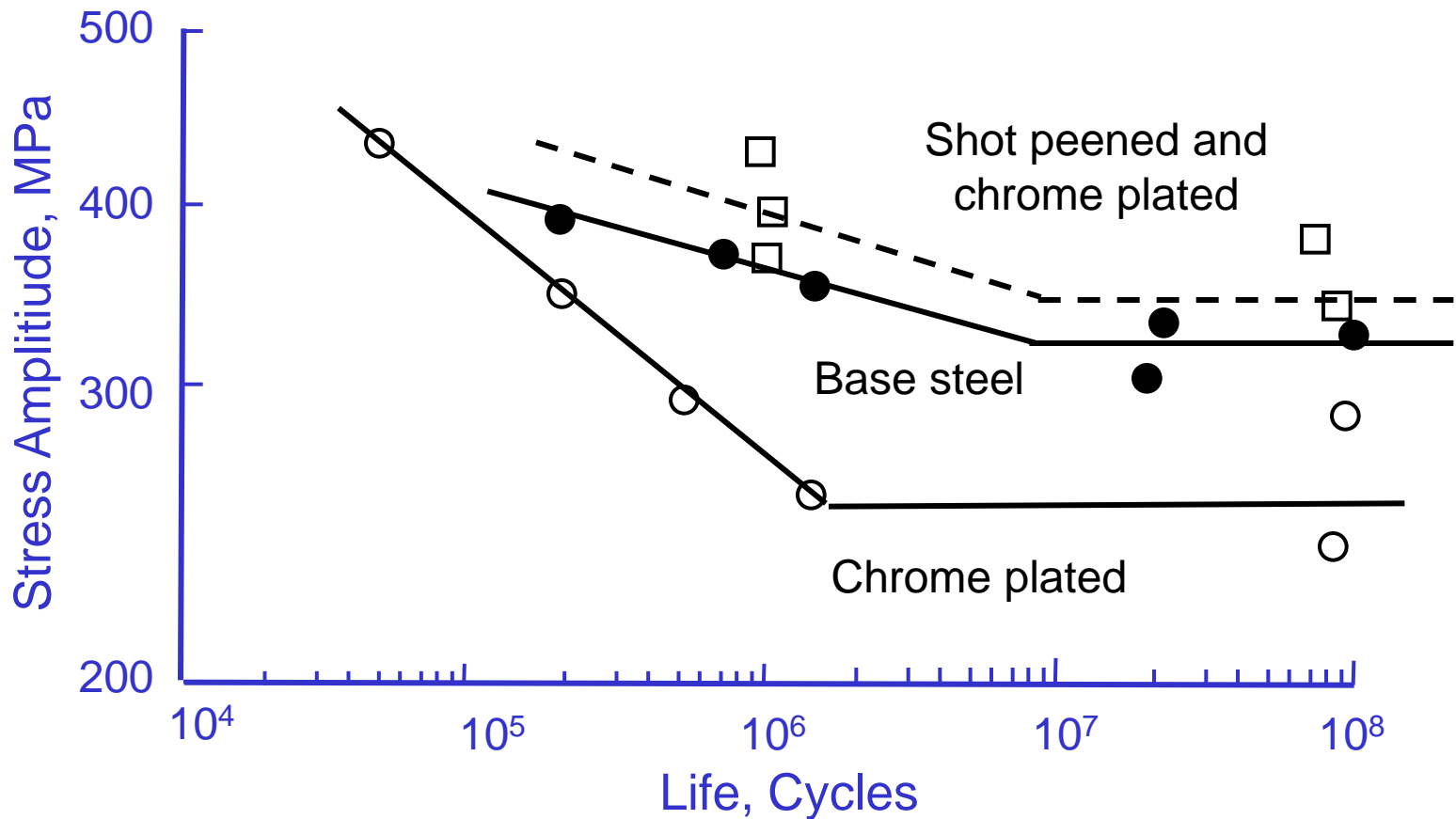

Almen, "Fatigue Loss and Gain by Electroplating", Product Engineering, Vol. 22, No. 5, 1951, 109-116

# Hard Chrome Plating

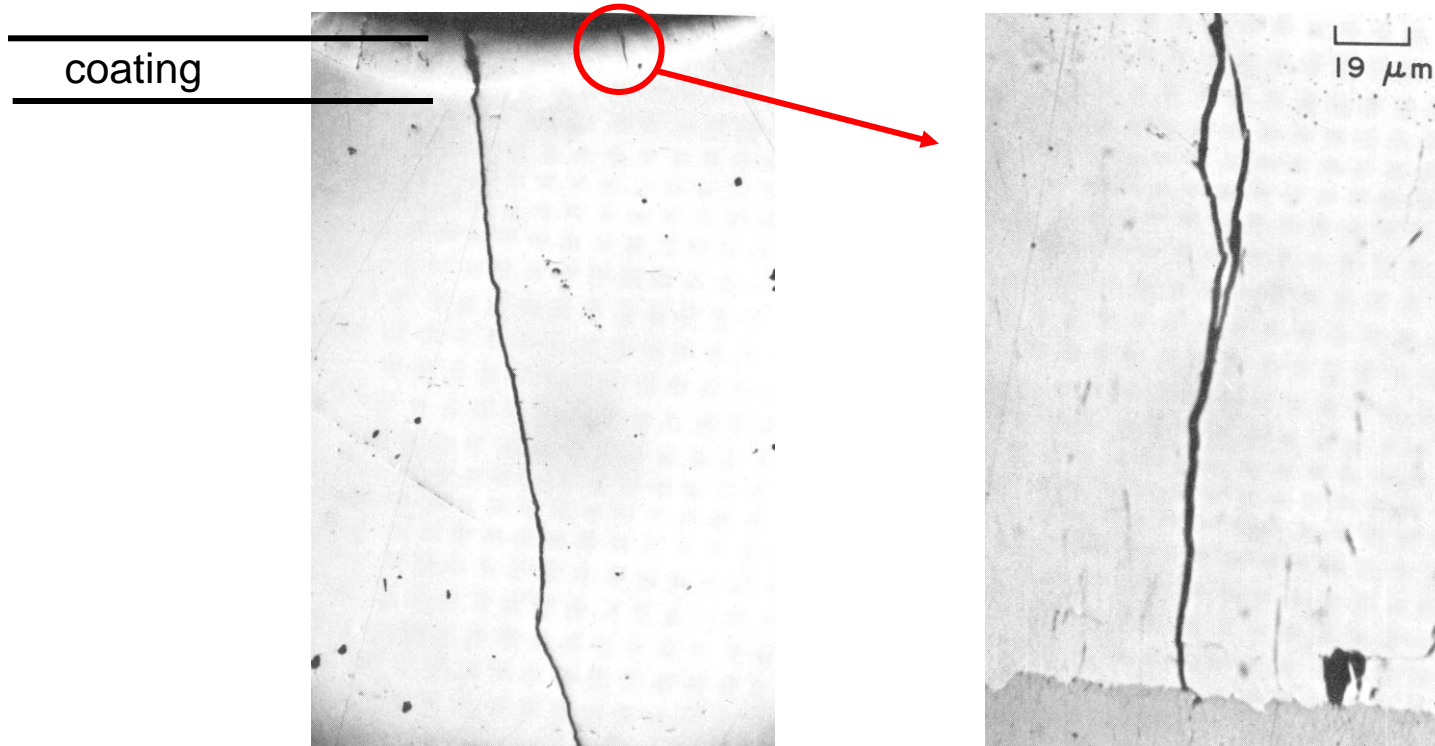

In addition to cracks, coatings frequently have high tensile residual stresses

Metals Handbook, Volume 9, Fractography and Atlas of Fractographs

# Galvanized Steel

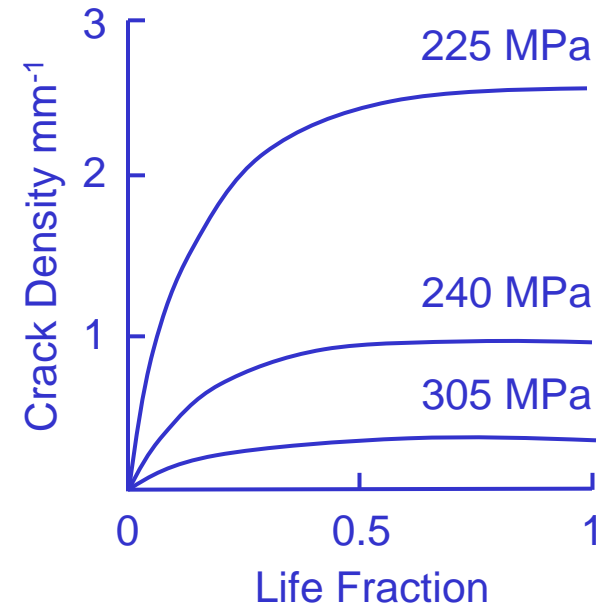
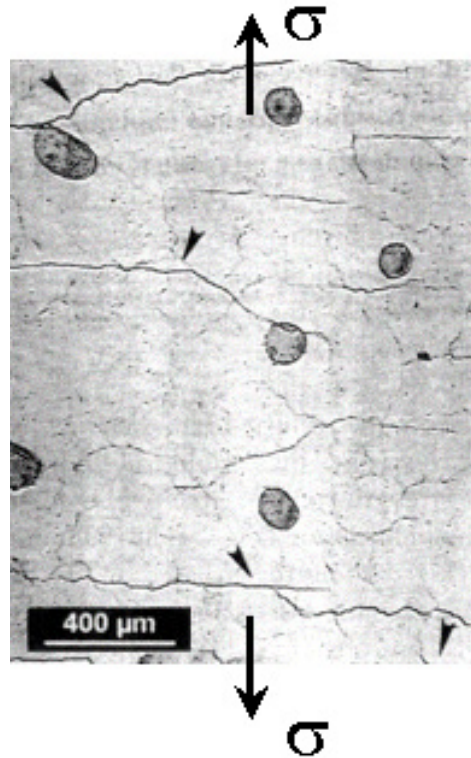
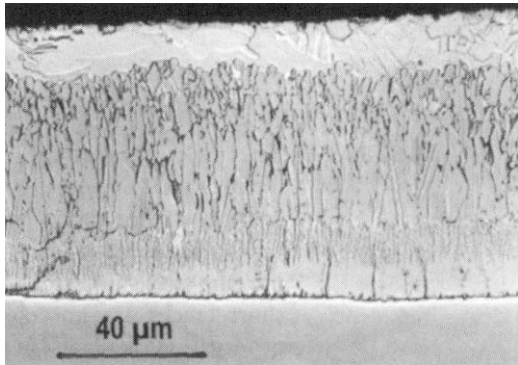

Vogt, Boussac, Foct, "Prediction of Fatigue Resistance of a Hot-dip Galvanized Steel"  
Fatigue and Fracture of Engineering Materials and Structures, Vol. 23, No. 1, 2001,33-40

# Fatigue Limit for Galvanized Steel

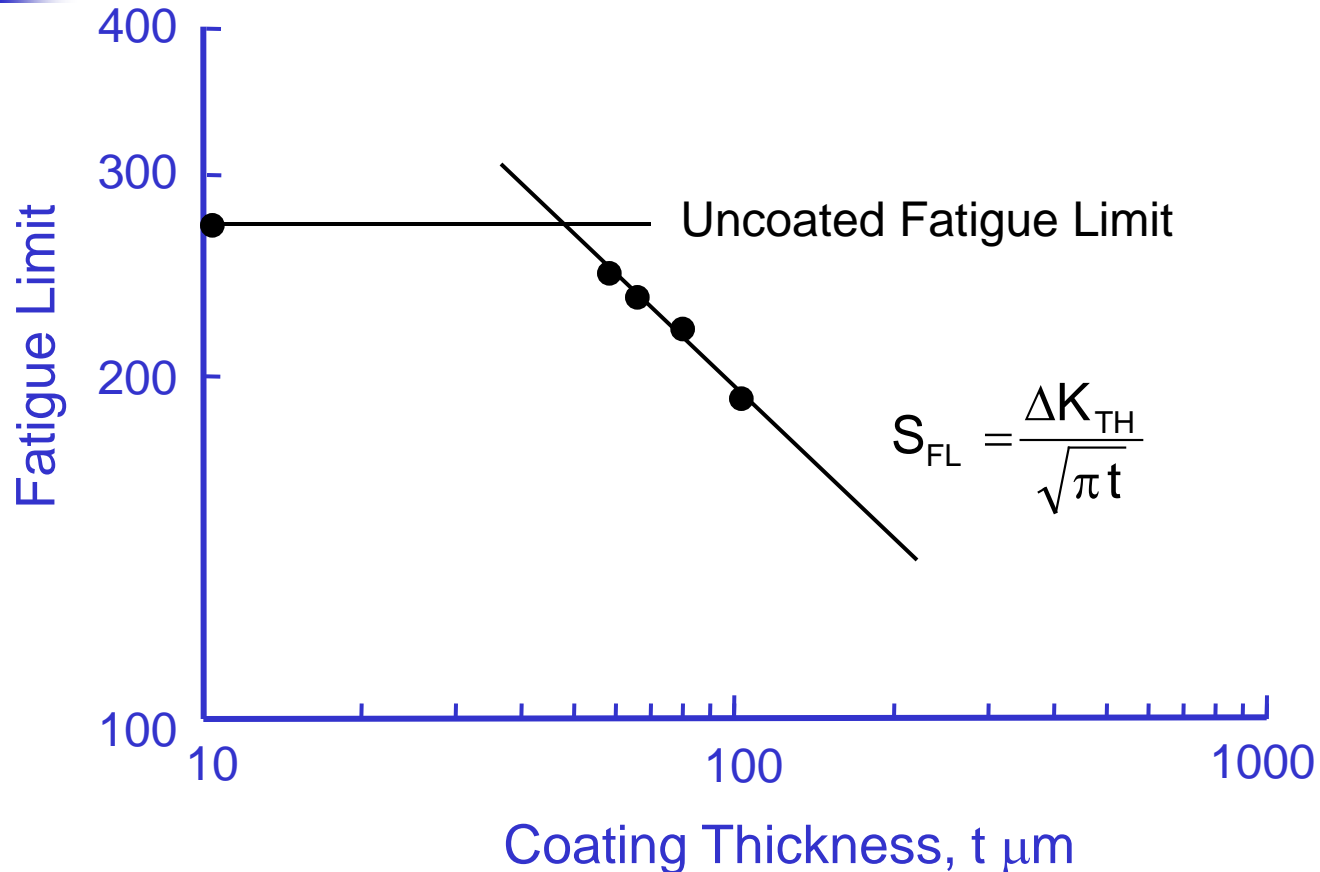

Coatings can be modeled with a crack equal to the coating thickness



# Anodized Aluminum

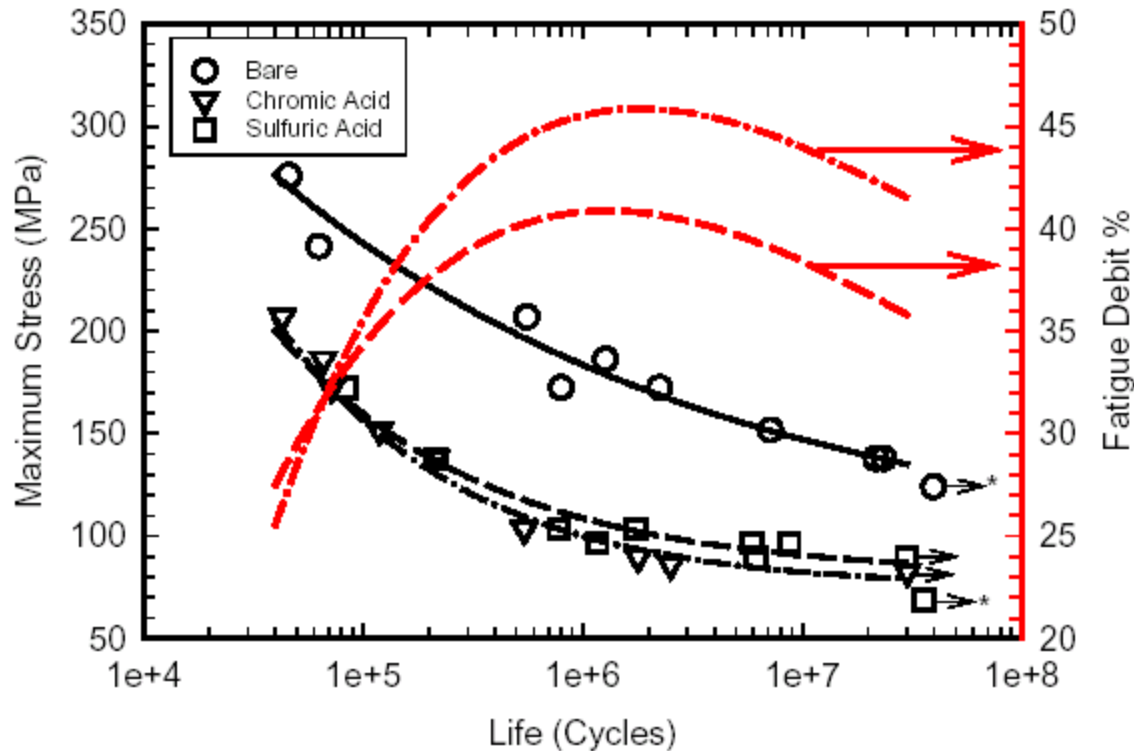

Rateick et. al. "Relationship of Microstructure to Fatigue Strength Loss in Anodized Aluminum-Copper Alloys"  
Aeromet 2004, June 2004

# Pitting at Cu Rich Constituent

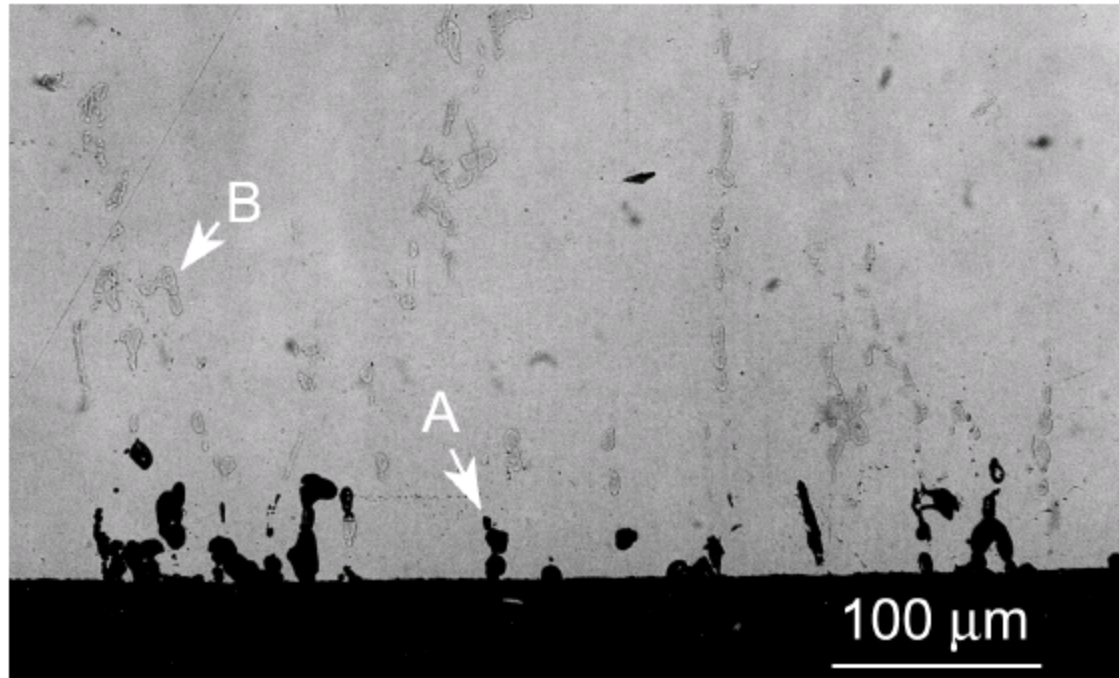

- AA2219-T851 plate cross sectioned immediately after anodizing
- A: Pits
- B: Cu rich constituent

# Foreign Object Damage

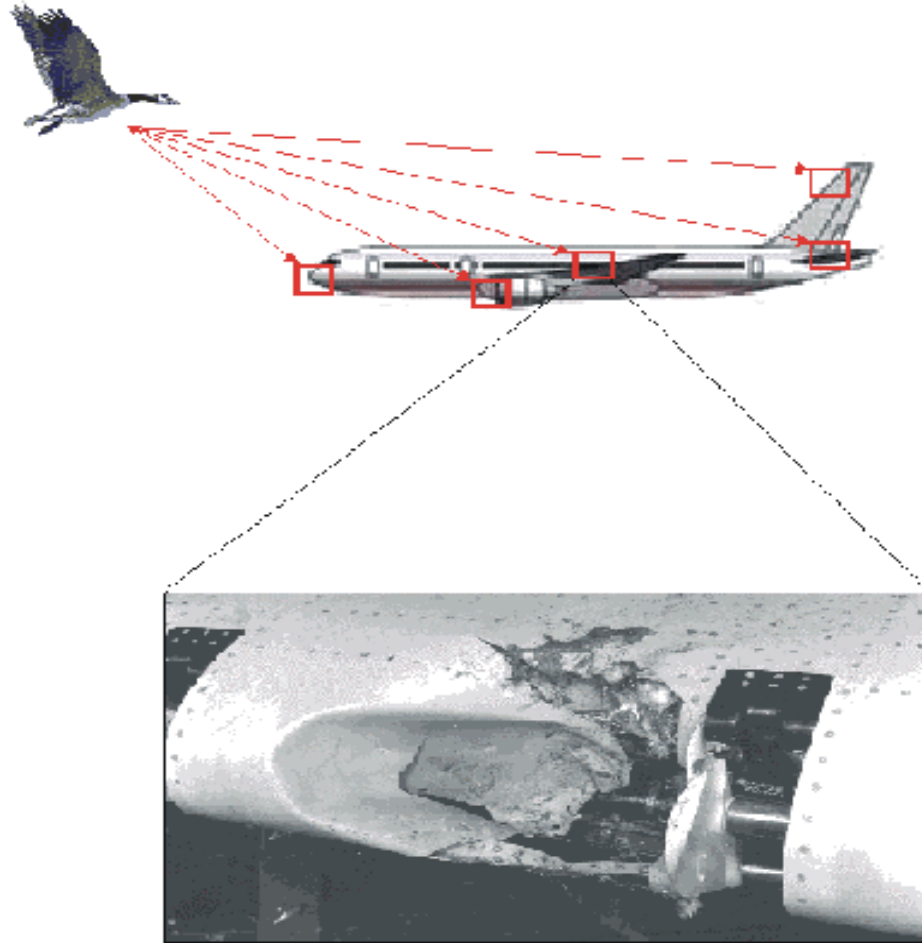

<http://www.eng.ox.ac.uk/~ftgwww/frontpage/fod2.html>

# Foreign Object Damage

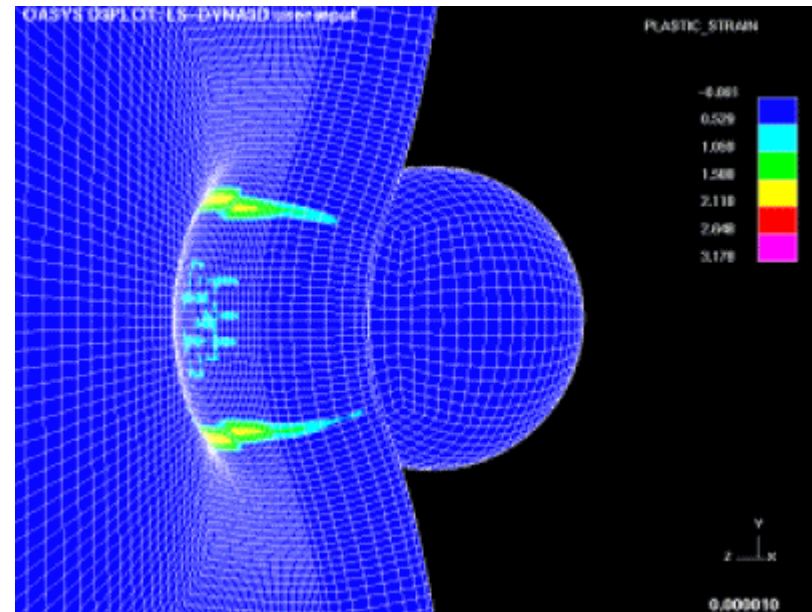
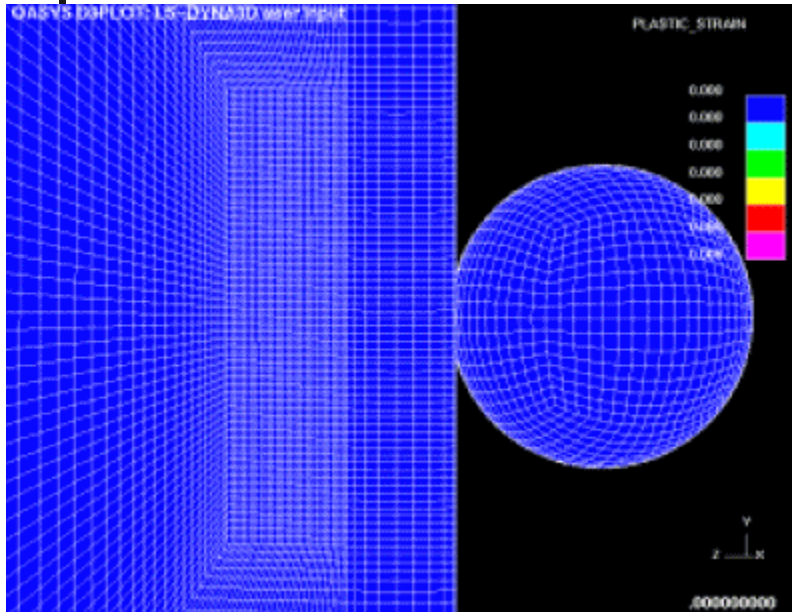

<http://www.eng.ox.ac.uk/~ftgwww/frontpage/fod2.html>

# Upper Control Arm



# Serial Number





# Things Worth Remembering

---

- Fatigue crack nucleation is a surface phenomena and everything about the surface affects the fatigue life
- Most of the design rules are conservative having been developed for materials of the 1950's

# Fatigue and Fracture

